

AUTOMATIC AIR VENT

BRAND NAME : **METRAFLEX**
COUNTRY : **U.S.A.**
MODEL : **MV-30**
SIZE : **1/2", 3/4", 1" DIA.**
MAX. WORKING PRESSURE : **300 PSI.**
CONNECTION : **NPT THREADED**

MATERIAL OF CONSTRUCTION

BODY : **CAST IRON**
COVER : **CAST IRON**
SEAT : **STAINLESS STEEL**
FLOAT : **STAINLESS STEEL**
GASKET : **GARLOCK # 3000**
(NON-ASBESTOS FIBER)

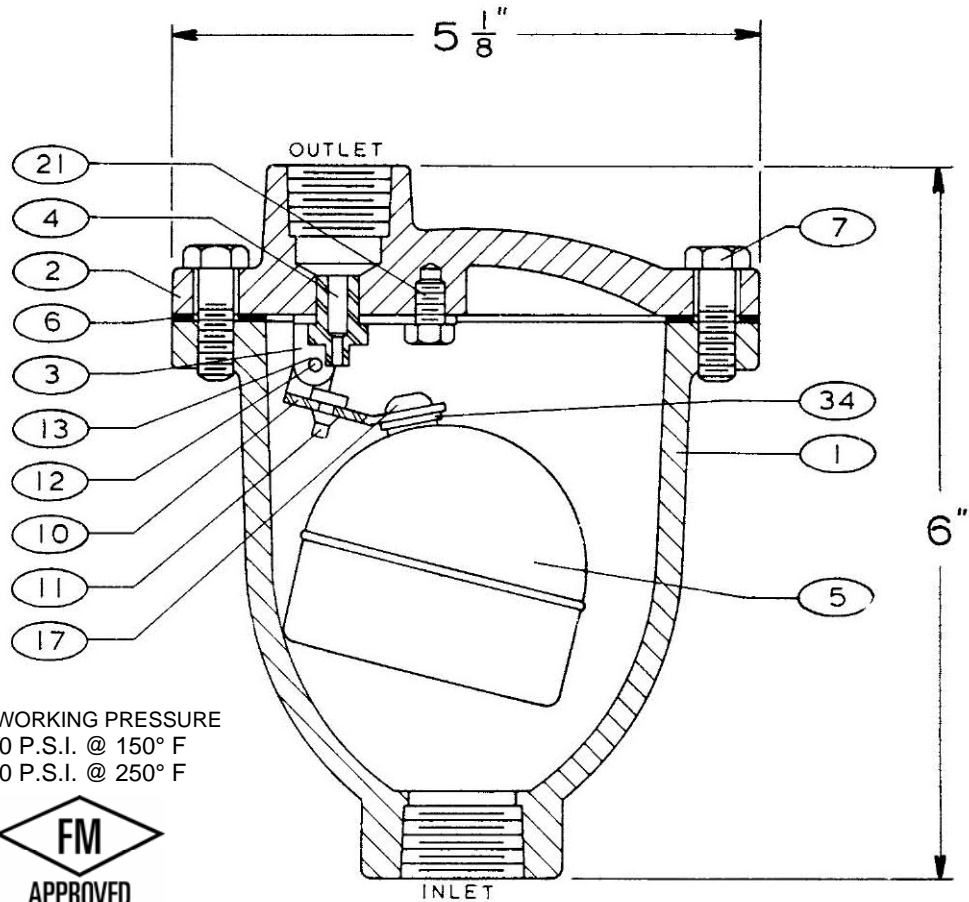

MAX. WORKING PRESSURE
 300 P.S.I. @ 150° F
 260 P.S.I. @ 250° F



PART NO.	NAME	MATERIAL	PART NO.	NAME	MATERIAL
1	BODY	CAST IRON A.S.T.M. A126, CLASS B	11	ORIFICE BUTTON	FLUOROELASATOMERS
2	COVER	CAST IRON A.S.T.M. A126, CLASS B	12	PIVOT PIN	STAINLESS STEEL S.A.E.30303
3	LEVER FRAME	STAINLESS STEEL A.S.T.M. A-240	13	PIN RETAINER	STAINLESS STEEL PH 15-7 MO
4	SEAT	STAINLESS STEEL S.A.E. 30303	14	PIPE PLUG	MALLEABLE IRON
5	FLOAT	STAINLESS STEEL A.S.T.M. A-240	17	FLOAT RETAINER	STAINLESS STEEL A.S.T.M. A276
6	GASKET	GARLOCK #3000 (NON-ASBESTOS)	21	LOCATOR	STAINLESS STEEL A.S.T.M. A276
7	COVER BOLT	ALLOY STEEL A.S.T.M. A449, GRADE 5	34	LOCK WASHER	STAINLESS STEEL A.S.T.M. A-240
10	FLOAT ARM	STAINLESS STEEL S.A.E. 30303			

NOTE: ALL SPECIFICATIONS AS LAST REVISED

QUANTITY	VALVE SIZE		MODEL NO.	INLET SIZE	OUTLET SIZE	MAX. TEMP.	ORIFICE SIZE	WEIGHT LBS.
	INCH	MM					300 P.S.I. MAX. W.P.	
	1/2"	15	1/2" -MV30	1/2" N.P.T.	1/2" N.P.T.	250° F	1/16"	8
	3/4"	20	3/4" -MV30	3/4" N.P.T.	1/2" N.P.T.	250° F	1/16"	8
	1"	25	1" - MV30	1" N.P.T	1/2" N.P.T.	250° F	1/16"	8

CUSTOMER _____

PROJECT _____

ENGINEER _____

ARCHITECT _____

PRO. OR P.O. NO. _____

Metraflex.
for pipes in motion

DESCRIPTION:
**METRAVENT AUTOMATIC
 AIR VENT, MODEL MV-30**

DRAWING BY: BMP	DATE: 7-18-07	DRAWING NO. MV-30 R1
--------------------	------------------	-------------------------