

Sprinkler Guards, Shields, and Intermediate Level Accessories

General Description

TYCO Sprinkler Guards and Shields are designed for use as accessories for sprinklers located in areas that make them susceptible to mechanical or physical damage.

Installation of Guards and Shields on Sprinklers form Intermediate Level Sprinkler assemblies intended for use in fire sprinkler systems designed in accordance with the standard installation rules recognized by the applicable Listing agency (that is, UL Listing is based on NFPA requirements).

Model G1 and G4 Sprinkler Guards, G1/S1 and G4/S3 Sprinkler Guard with Shield assemblies, and S2, S4 and S5 Sprinkler Shields are compatible with specific types of Series TY-B, TY-FRB, TY-L, and TY-FRL sprinklers (Ref. Table A).

Model G2 Sprinkler Guard, WSG-2 Sprinkler Guard with Shield assembly, and WS-2 Sprinkler Shield are compatible with Series ELO-231, ELO-231B, and ELO-231FRB sprinklers (Ref. Table A).

The Model G5 Sprinkler Guard is compatible with Series DS-1 dry-type sprinklers (Ref. Table A).

In addition to providing protection from mechanical or physical damage, Model G1/S1, G4/S3, and WSG-2 Guard with Shield assemblies protect upright sprinklers from water spray of higher elevation sprinklers (e.g., rack storage sprinkler installations).

IMPORTANT

Always refer to Technical Data Sheet TFP700 for the "INSTALLER WARNING" that provides cautions with respect to handling and installation of sprinkler systems and components. Improper handling and installation can permanently damage a sprinkler system or its components and cause the sprinkler to fail to operate in a fire situation or cause it to operate prematurely.



Pendent sprinklers located in areas not susceptible to the threat of mechanical or physical damage can be equipped with Model S2, S4, S5 and WS-2 Shields for protection from water spray of higher elevation sprinklers.

NOTICE

Sprinkler Guards, Shields, and Guard with Shield assemblies described herein must be installed and maintained in compliance with this document and with the applicable standards of the National Fire Protection Association, in addition to the standards of any authorities having jurisdiction. Failure to do so may impair the performance of these devices.

The Model G5 Sprinkler Guard cannot be installed in recessed applications. The Model G5 Guard can be installed only on Series DS-1 sprinklers with standard and deep escutcheons, as well as sprinklers without escutcheons.

The owner is responsible for maintaining their fire protection system and devices in proper operating condition. Contact the installing contractor or product manufacturer with any questions.

Technical Data

Model G1 and G4 Sprinkler Guards are re-designations for Gem F938 and F937 respectively.

Model G1/S1 and G4/S3 Sprinkler Guard with Shield assemblies are re-designations for Gem F938/Q-76 and F937/Q-75 respectively.

Model G2 Sprinkler Guard, WSG-2 Sprinkler Guard with Shield, and WS-2 Sprinkler Shield are re-designations for Central G2, WSG-2, and WS-2 respectively.

Approvals

UL and C-UL Listed
FM Approved
Ref. Table A

Finishes*

Plain Brass, Red Painted, Chrome Plated, Zinc Coated, and Zinc Chromate

* Refer to Ordering Procedure for applicability

Physical Characteristics

Sprinkler Guards, Shields, and Guard with Shield assemblies are Carbon Steel; O-Rings are EPDM

Sprinkler							Compatibility and Approvals		
Model	Data Sheet	SIN	Orientation	K-Factor	Thread Size NPT	Mounting Location	Guard	Guard with Shield	Shield
TY-B	TFP151	TY1151	Upright	2.8	1/2"	Thread Relief	G1 (1, 3)	N/A	N/A
	TFP151	TY1251	Pendent	2.8	1/2"	Thread Relief	G1 (1, 3)	N/A	N/A
	TFP152	TY315	Upright	5.6	1/2"	Thread Relief	G1 (1, 2, 3)	G1/S1 (1,2, 3)	N/A
	TFP152	TY325	Pendent	5.6	1/2"	Thread Relief	G1 (1, 2, 3)	N/A	S2 (1, 2, 3)
	TFP151	TY3151	Upright	5.6	1/2"	Thread Relief	G1 (1, 2, 3), G4 (2)	G1/S1 (1, 2, 3)	N/A
	TFP151	TY3251	Pendent	5.6	1/2"	Thread Relief	G1 (1, 2, 3), G4 (2)	N/A	S2 (1, 2, 3)
	TFP351	TY3153	Upright	5.6	1/2"	Factory Assm	N/A	N/A	(1, 2, 3)
	TFP151	TY4851	Upright	8.0	1/2"	Thread Relief	G1 (1, 2, 3)	N/A	N/A
	TFP151	TY4951	Pendent	8.0	1/2"	Thread Relief	G1 (1, 2, 3)	N/A	N/A
	TFP151	TY4151	Upright	8.0	3/4"	Thread Relief	G1 (1, 2, 3)	G1/S1 (1, 2, 3)	N/A
	TFP151	TY4251	Pendent	8.0	3/4"	Thread Relief	G1 (1, 2, 3)	N/A	S2 (1, 2, 3)
	TFP351	TY4153	Upright	8.0	3/4"	Factory Assm	N/A	N/A	(1, 2, 3)
	TFP161	TY3351	HSW	5.6	1/2"	Thread Relief	G4 (1, 2, 3)	N/A	N/A
	TFP161	TY3451	VSW	5.6	1/2"	Thread Relief	G4 (1, 3)	N/A	N/A
TY-FRB	TFP171	TY1131	Upright	2.8	1/2"	Thread Relief	G1 (1, 3)	N/A	N/A
	TFP171	TY1231	Pendent	2.8	1/2"	Thread Relief	G1 (1, 3)	N/A	N/A
	TFP172	TY313	Upright	5.6	1/2"	Thread Relief	G1 (1, 2, 3)	G1/S1 (1,2, 3)	N/A
	TFP172	TY323	Pendent	5.6	1/2"	Thread Relief	G1 (1, 2, 3)	N/A	S2 (1, 2, 3)
	TFP171	TY3131	Upright	5.6	1/2"	Thread Relief	G1 (1, 2, 3), G4 (2)	G1/S1 (1, 3)	N/A
	TFP171	TY3231	Pendent	5.6	1/2"	Thread Relief	G1 (1, 2, 3), G4 (2)	N/A	S2 (1, 2, 3)
	TFP356	TY3133	Upright	5.6	1/2"	Factory Assm	N/A	N/A	(1, 2, 3)
	TFP171	TY4131	Upright	8.0	3/4"	Thread Relief	G1 (1, 2, 3)	G1/S1 (1, 3)	N/A
	TFP171	TY4231	Pendent	8.0	3/4"	Thread Relief	G1 (1, 2, 3)	N/A	S2 (1, 2, 3)
	TFP356	TY4133	Upright	8.0	3/4"	Factory Assm	N/A	N/A	(1, 2, 3)
	TFP176	TY3331	HSW	5.6	1/2"	Thread Relief	G4 (1, 3)	N/A	N/A
	TFP176	TY3431	VSW	5.6	1/2"	Thread Relief	G4 (1, 3)	N/A	N/A
ELO-231	TFP340	TY5111	Upright	11.2	3/4"	Thread Relief	G2 (1, 2, 3)	WSG-2 (1, 3)	N/A
	TFP340	TY5211	Pendent	11.2	3/4"	Thread Relief	G2 (1, 2, 3)	N/A	WS-2 (1, 3)
	TFP340	TY5811	Upright	11.2	3/4"	Thread Relief	G2 (1, 2, 3)	WSG-2 (1, 3)	N/A

Notes:
1. UL Listed
2. FM Approved
3. C-UL Listed
N/A Not Applicable

TABLE A (1 OF 2)
SPRINKLER GUARD AND SHIELD
LABORATORY LISTINGS AND APPROVALS

Design Criteria

In accordance with the requirements of the NFPA, Sprinkler Guards and Shields shall be Listed. Guards and Shields are Listed or Approved for use only with specific sprinklers:

Models G1, G4, G1/S1, G4/S3, S2, S4, and S5 must only be used with Series TY-B, TY-FRB, TY-L, and TY-FRL sprinklers.

Model G2, WSG-2, and WS-2 must only be used with Series ELO-231, ELO-231B, and ELO-231FRB sprinklers.

Model G5 must only be used with the Series DS-1 sprinklers.

Refer to Table A for specific compatibility and Listings or Approvals.

Sprinkler							Compatibility and Approvals		
Model	Data Sheet	SIN	Orientation	K-Factor	Thread Size NPT	Mounting Location	Guard	Guard with Shield	Shield
ELO-231B	TFP342	TY5151	Upright	11.2	3/4"	Thread Relief	G2 (1, 2, 3)	WSG-2 (1, 3)	N/A
	TFP342	TY5251	Pendent	11.2	3/4"	Thread Relief	G2 (1, 2, 3)	N/A	WS-2 (1, 3)
	TFP342	TY5851	Upright	11.2	3/4"	Thread Relief	G2 (1, 2, 3)	WSG-2 (1, 3)	N/A
ELO- 231FRB	TFP344	TY5131	Upright	11.2	3/4"	Thread Relief	G2 (1, 2, 3)	WSG-2 (1, 3)	N/A
	TFP344	TY5231	Pendent	11.2	3/4"	Thread Relief	G2 (1, 2, 3)	N/A	WS-2 (1, 2, 3)
TY-L	TFP110	TY3111	Upright	5.6	1/2"	Wrench Area	G1 (2), G4 (1, 3)	G4/S3 (1, 3)	N/A
	TFP350	TY3113	Upright	5.6	1/2"	Factory Assm	N/A	N/A	(1, 2, 3)
	TFP110	TY3211	Pendent	5.6	1/2"	Wrench Area	G1 (2), G4 (1, 3)	N/A	S5 (1, 2, 3)
	TFP110	TY4811	Upright	8.0	1/2"	Wrench Area	G4 (1, 2, 3)	G4/S3 (1, 3)	N/A
	TFP110	TY4911	Pendent	8.0	1/2"	Wrench Area	G4 (1, 3)	N/A	N/A
	TFP110	TY4111	Upright	8.0	3/4"	Wrench Area	G4 (2)	N/A	N/A
	TFP350	TY4113	Upright	8.0	3/4"	Factory Assm	N/A	N/A	(1, 2, 3)
	TFP110	TY4211	Pendent	8.0	3/4"	Wrench Area	G4 (1, 3)	N/A	(1, 2, 3)
TY-FRL	TFP130	TY1121	Upright	2.8	1/2"	Wrench Area	G4 (1, 3)	N/A	N/A
	TFP130	TY1221	Pendent	2.8	1/2"	Wrench Area	G4 (1, 3)	N/A	N/A
	TFP130	TY3121	Upright	5.6	1/2"	Wrench Area	G4 (1, 2, 3)	G4/S3 (1, 3)	N/A
	TFP355	TY3123	Upright	5.6	1/2"	Factory Assm	N/A	N/A	(1, 2, 3)
	TFP130	TY3221	Pendent	5.6	1/2"	Wrench Area	G4 (1, 3)	N/A	S4 (1, 2, 3)
	TFP140	TY3321	HSW	5.6	1/2"	Wrench Area	G4 (1, 3)	N/A	N/A
	TFP130	TY4121	Upright	8.0	3/4"	Wrench Area	G4 (1, 2, 3)	G4/S3 (1, 3)	N/A
	TFP355	TY4123	Upright	8.0	3/4"	Factory Assm	N/A	N/A	(1, 2, 3)
DS-1	TFP500	TY3255	Pendent	5.6	N/A	Wrench Area	G5* (1)	N/A	N/A
	TFP510	TY3235	Pendent	5.6	N/A	Wrench Area	G5* (1)	N/A	N/A
	TFP500	TY3355	HSW	5.6	N/A	Wrench Area	G5* (1)	N/A	N/A
	TFP510	TY3335	HSW	5.6	N/A	Wrench Area	G5* (1)	N/A	N/A
DS-1 Stainless Steel	TFP560	TY3230	Pendent	5.6	N/A	Wrench Area	G5* (1)	N/A	N/A
	TFP560	TY3250	Pendent	5.6	N/A	Wrench Area	G5* (1)	N/A	N/A
	TFP560	TY3337	HSW	5.6	N/A	Wrench Area	G5* (1)	N/A	N/A
	TFP560	TY3357	HSW	5.6	N/A	Wrench Area	G5* (1)	N/A	N/A

Notes:
1. UL Listed
2. FM Approved
3. C-UL Listed
N/A Not Applicable

* Model G5 Guard can be installed only on sprinklers with standard and deep escutcheons, as well as sprinklers without escutcheons. G5 Guard cannot be installed in recessed applications.

**TABLE A (2 OF 2)
SPRINKLER GUARD AND SHIELD
LABORATORY LISTINGS AND APPROVALS**

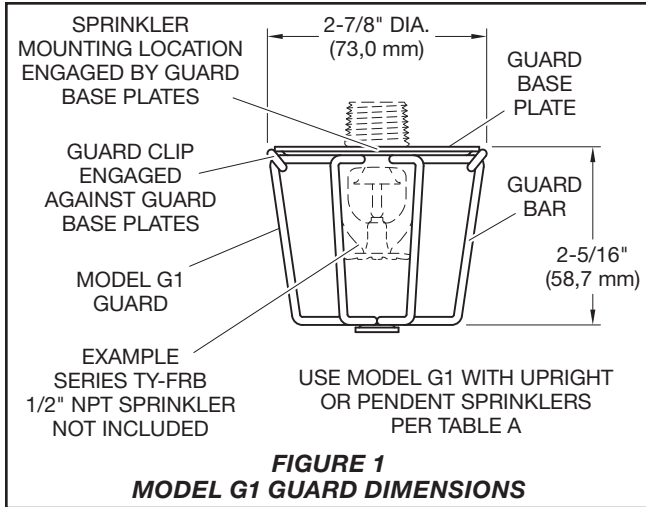

FIGURE 1
MODEL G1 GUARD DIMENSIONS

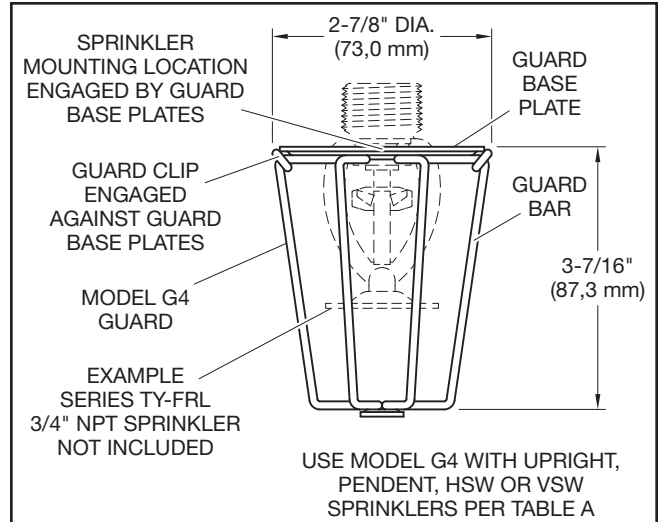

FIGURE 2
MODEL G4 GUARD DIMENSIONS

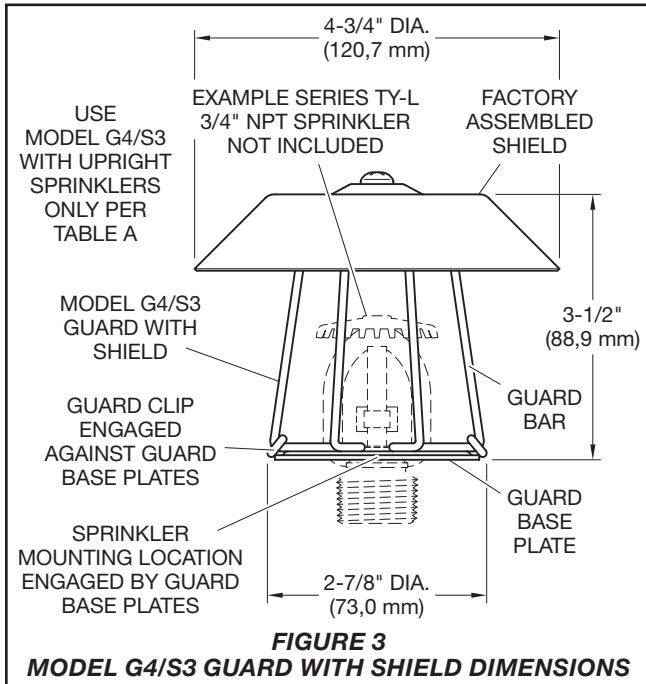

FIGURE 3
MODEL G4/S3 GUARD WITH SHIELD DIMENSIONS

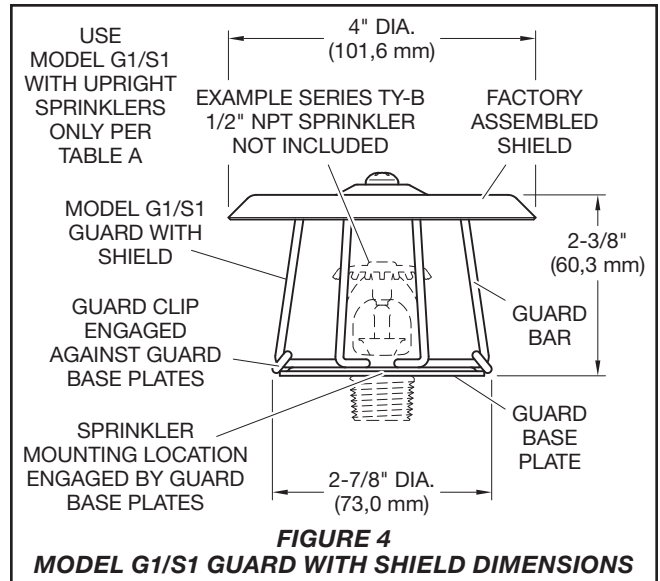

FIGURE 4
MODEL G1/S1 GUARD WITH SHIELD DIMENSIONS

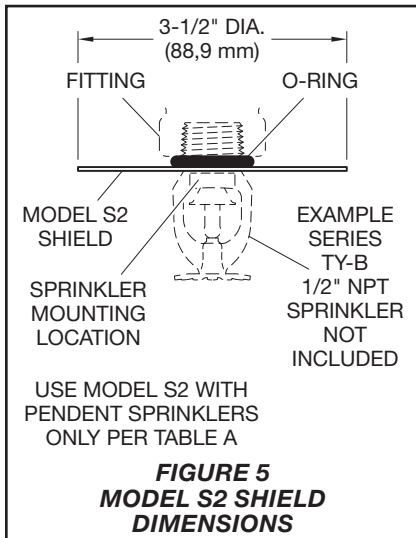

FIGURE 5
MODEL S2 SHIELD DIMENSIONS

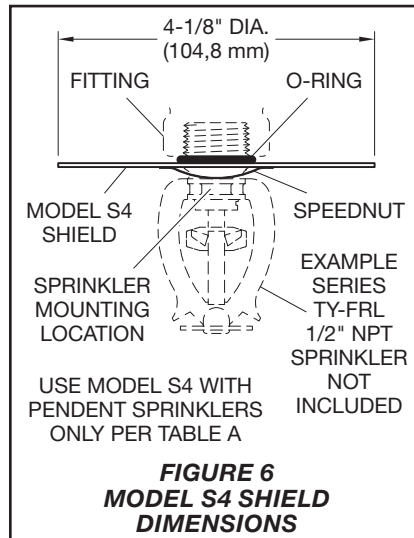

FIGURE 6
MODEL S4 SHIELD DIMENSIONS

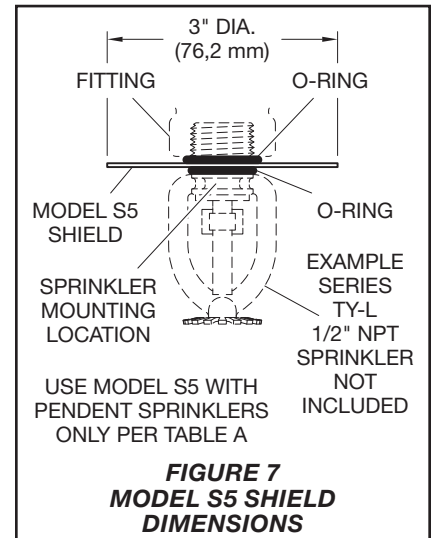
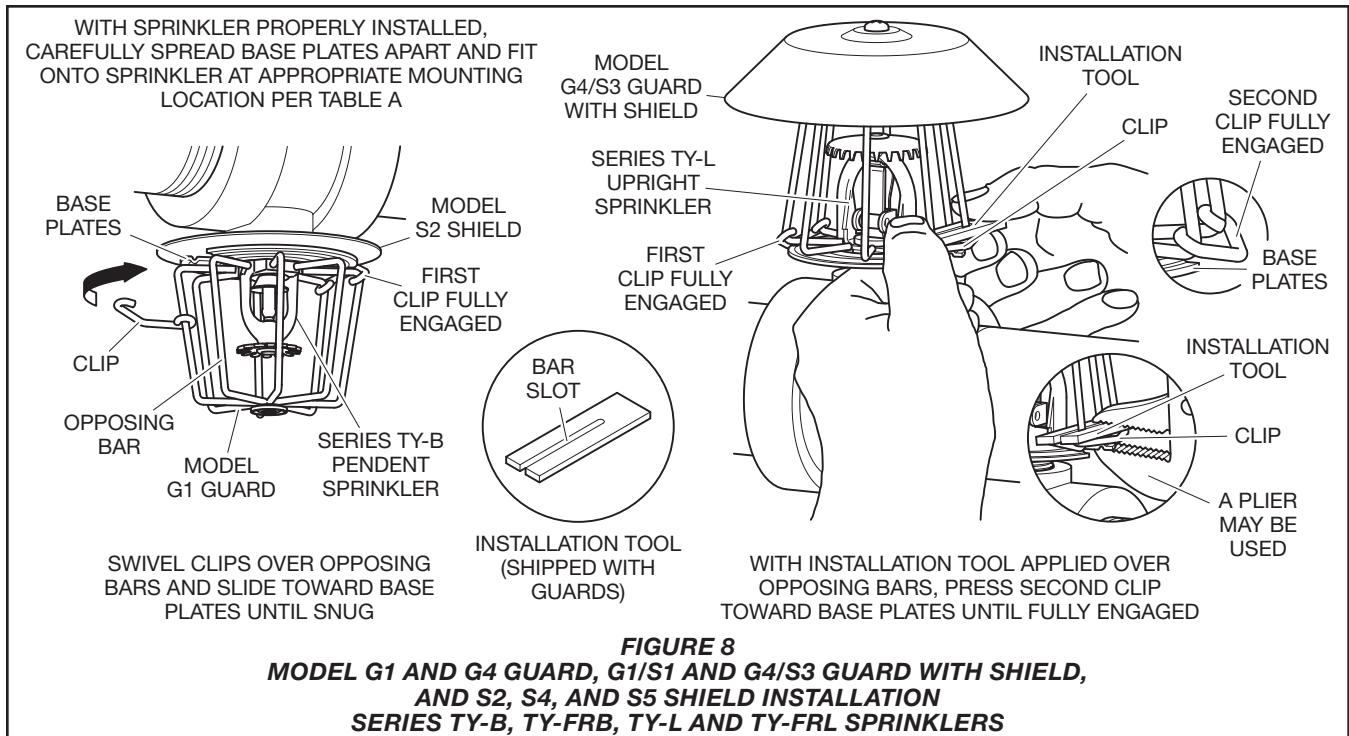

FIGURE 7
MODEL S5 SHIELD DIMENSIONS



Installation

Series TY-B, TY-FRB, TY-L, TY-FRL Sprinklers

TYCO Model G1 and G4 Sprinkler Guards, G1/S1 and G4/S3 Sprinkler Guard with Shield assemblies, and Model S2, S4, and S5 Sprinkler Shields must be installed in accordance with this section. (Ref. Figures 1 through 8)

G1 and G4 Guard and G1/S1 and G4/S3 Guard with Shield Installation

Step 1. Install sprinkler in accordance with applicable technical data sheet (Ref. Table A).

Step 2. With the Clips loose, carefully spread two halves of Guard sufficiently to clear sprinkler frame and deflector from side and mount Guard on sprinkler.

Step 3. Engage sprinkler mounting location (Ref. Table A) by Guard Base Plates.

Step 4. With Base Plates positioned on sprinkler mounting feature, slide Clips away from Base Plates and swivel them to engage Bars of opposing halves of Guard.

Step 5. Slide Clips until seated against Base Plates.

Step 6. Fully engage Clips against Base Plates.

Note: A Guard Installation Tool may be used to reduce effort required to fully engage Clips. Additionally, common pliers can be used to facilitate engagement of Clips.

NOTICE

Both Clips must be seated and fully engaged against Base Plates to complete installation.

Guard Base Plates and Bars may be oriented in any position axially relative to sprinkler frame arms.

S2, S4 and S5 Shield Installation

Notes: Install Shield on pendent sprinklers alone or in conjunction with G1 or G4 Sprinkler Guard.

Assemble Shield onto sprinkler prior to installing sprinkler into sprinkler fitting.

Step A. Install Speednut on TY-FRL sprinkler (Ref. Figure 6) or O-Ring on TY-L sprinkler (Ref. Figure 7).

Step B. With the stamped markings facing toward deflector thread Shield onto sprinkler threads to end nearest frame arms or until flush with Speednut or O-Ring as applicable.

Note: Final installation step is easier to complete if Shield is not assembled onto sprinkler beyond end of threads.

Step C. Install O-Ring over sprinkler threads until flush against Shield.

Step D. Install sprinkler into sprinkler fitting in accordance with applicable sprinkler data sheet (Ref. Table A).

Step E. Install Guard (pendent applications as applicable).

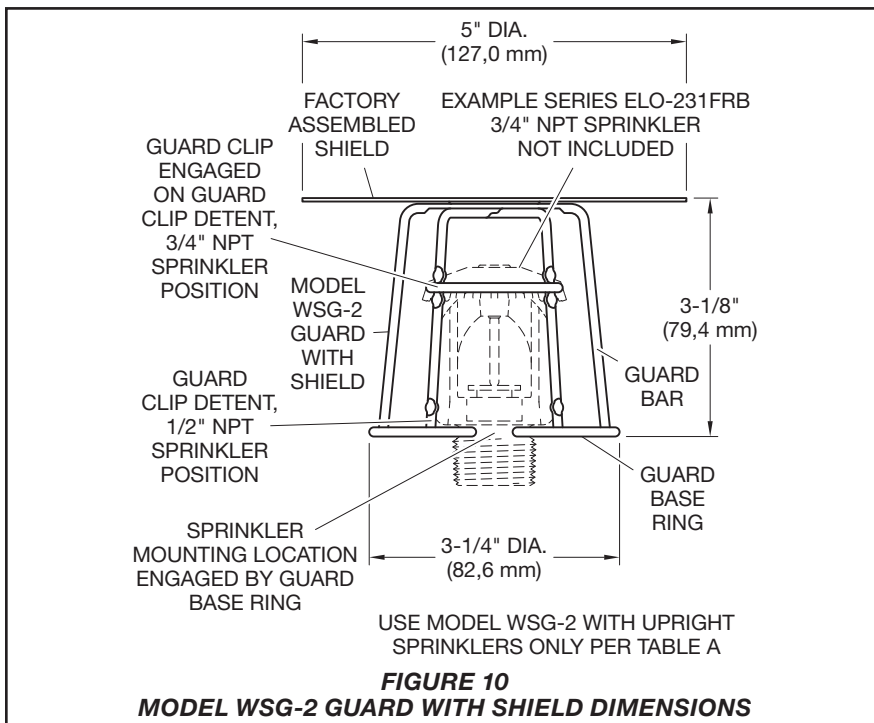
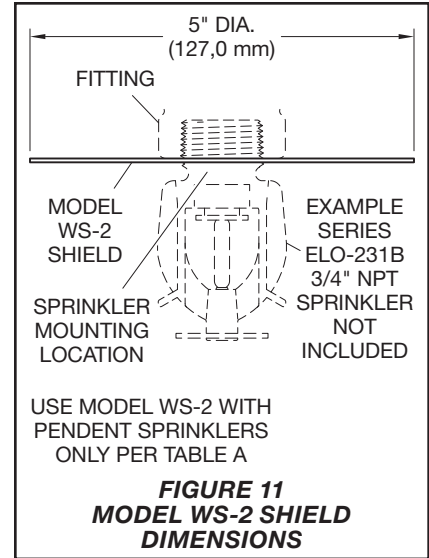
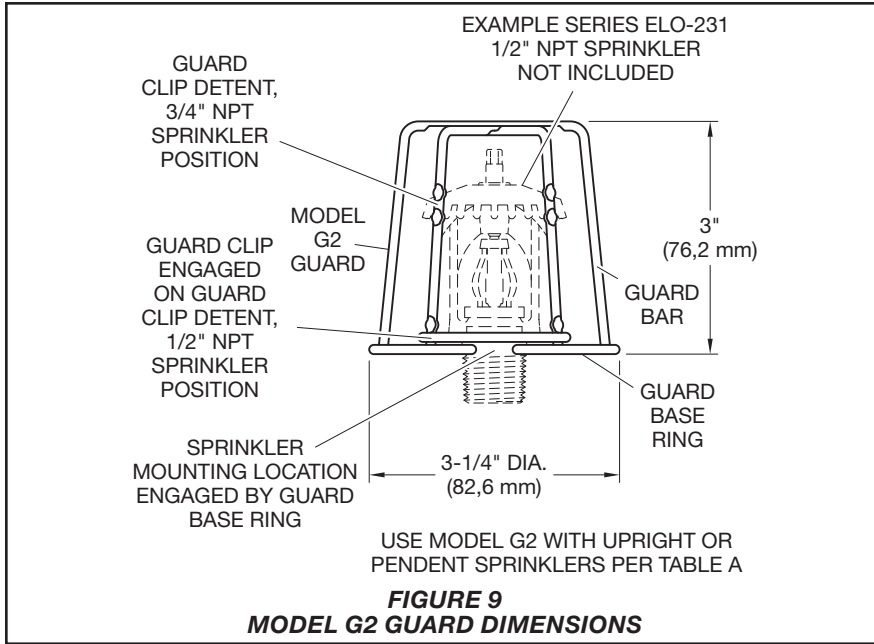

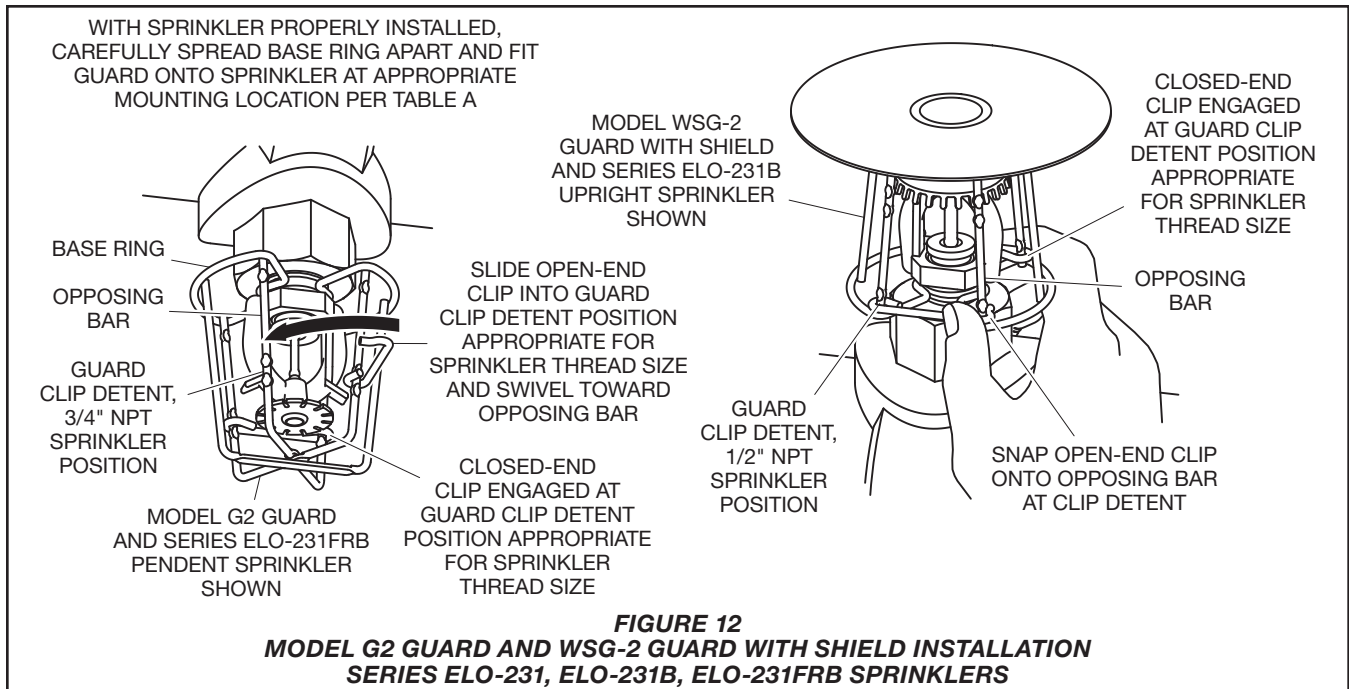

Installation

Series ELO-231, ELO-231B, and ELO-231FRB Sprinklers

TYCO Model G2 Sprinkler Guards, WSG-2 Sprinkler Guard with Shield assemblies, and Model WS-2 Sprinkler Shields must be installed in accordance with this section. (Ref. Figures 9 through 12)

G2 Guard and WSG-2 Guard with Shield Installation

Step 1. Install sprinkler in accordance with applicable technical data sheet (Ref. Table A).

Step 2. With the Clips loose, carefully spread two halves of Guard sufficiently to clear sprinkler frame and deflector from side and mount Guard on sprinkler.

Step 3. Engage sprinkler mounting location (Ref. Table A) by inner diameter of Guard Base Ring.

Step 4. With Base Ring positioned on sprinkler mounting feature, slide Clips away from Base Ring and swivel them to engage Bars of opposing halves of Guard.

Step 5. Slide Clips until Guard Clip Detents applicable to sprinkler thread size are engaged. Two sets of detents are featured: Set farthest from Base Ring accommodates 3/4\" NPT sprinklers; Set closest to Base Ring accommodates 1/2\" NPT sprinklers.

Notes: Ensure tight fit between Clip and Detents. If loose, carefully bend Clip slightly and repeat process until tight fit is obtained.

Clips must seat securely in appropriate Detents to be considered fully engaged and in order to complete installation.

Guard Base Ring and Bars may be oriented in any position axially relative to sprinkler frame arms.

WS-2 Shield Installation

Notes: Install Model WS-2 Shield on pendent sprinklers alone or in conjunction with G2 Sprinkler Guard.

Assemble Shield onto sprinkler prior to installing sprinkler into sprinkler fitting.

Step A. With the stamped markings facing toward deflector thread Shield onto sprinkler threads to end nearest frame arms.

Note: Final installation step is easier to complete if Shield is not assembled onto sprinkler beyond end of threads.

Step B. Install sprinkler into sprinkler fitting in accordance with applicable sprinkler data sheet (Ref. Table A).

Step C. Rotate Shield clockwise until flush against face of sprinkler fitting.

Step D. Install Guard (pendent applications as applicable).

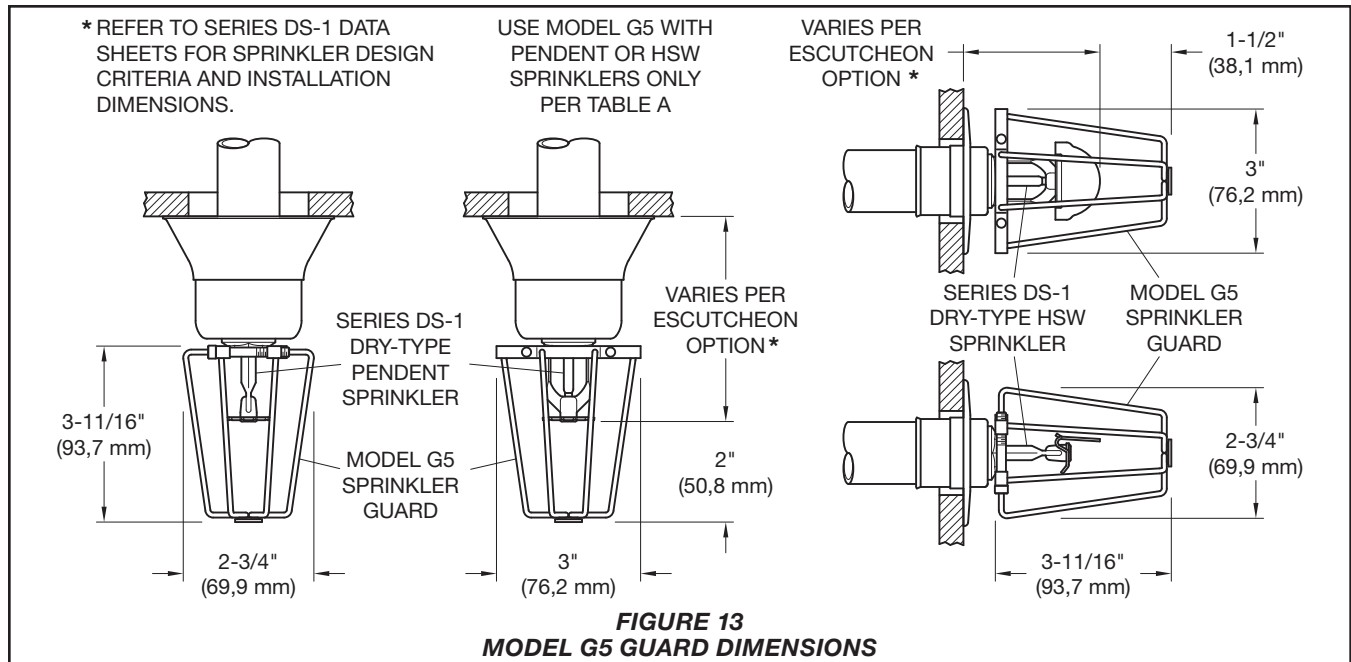

Installation

Series DS-1 Sprinklers

TYCO Model G5 Sprinkler Guards must be installed in accordance with this section. (Ref. Figures 13 and 14)

G5 Guard Installation

NOTICE

This procedure requires a 9/64" (3,5 mm) Allen Wrench.

Step 1. Install sprinkler in accordance with applicable technical data sheet (Ref. Table A).

Step 2. Loosen Guard Screws and carefully separate halves of Guard (Ref. Figure 14A).

Note: G5 Sprinkler Guard is designed to fit over sprinkler deflector without removing Screws. However, if necessary to provide adequate clearance over deflector, loosen or remove Screws and separate Base Plates.

Step 3. Remove sprinkler bulb protector and carefully pass Guard over deflector without damaging sprinkler. Alter alignment as necessary (Ref. Figure 14B).

Step 4. Align centerline of Guard with centerline of sprinkler while guiding Base Plates toward sprinkler.

Step 5. Position Grips on sprinkler wrench flats. Proper position is achieved when Base Plates are seated against sprinkler frame base (Ref. Figure 14C).

Step 6. While firmly holding Guard in position against sprinkler frame base, alternately tighten Screws with 9/64" (3,5 mm) Allen Wrench until evenly snug and Grips uniformly engage sprinkler wrench flats (Ref. Figure 14C).

Step 7. Evenly apply final torque of 5 to 6 ft.-lbs. to both Screws (Ref. Figure 14C).

Step 8. Inspect Guard installation to verify:

- Guard centerline is aligned with sprinkler centerline
- Base Plates are fully seated against sprinkler frame base
- Grips are evenly engaged with sprinkler wrench flats
- Screws are equally engaged across Base Plates

NOTICE

Base Plates must seat against sprinkler frame base to be fully engaged and in order to complete installation.

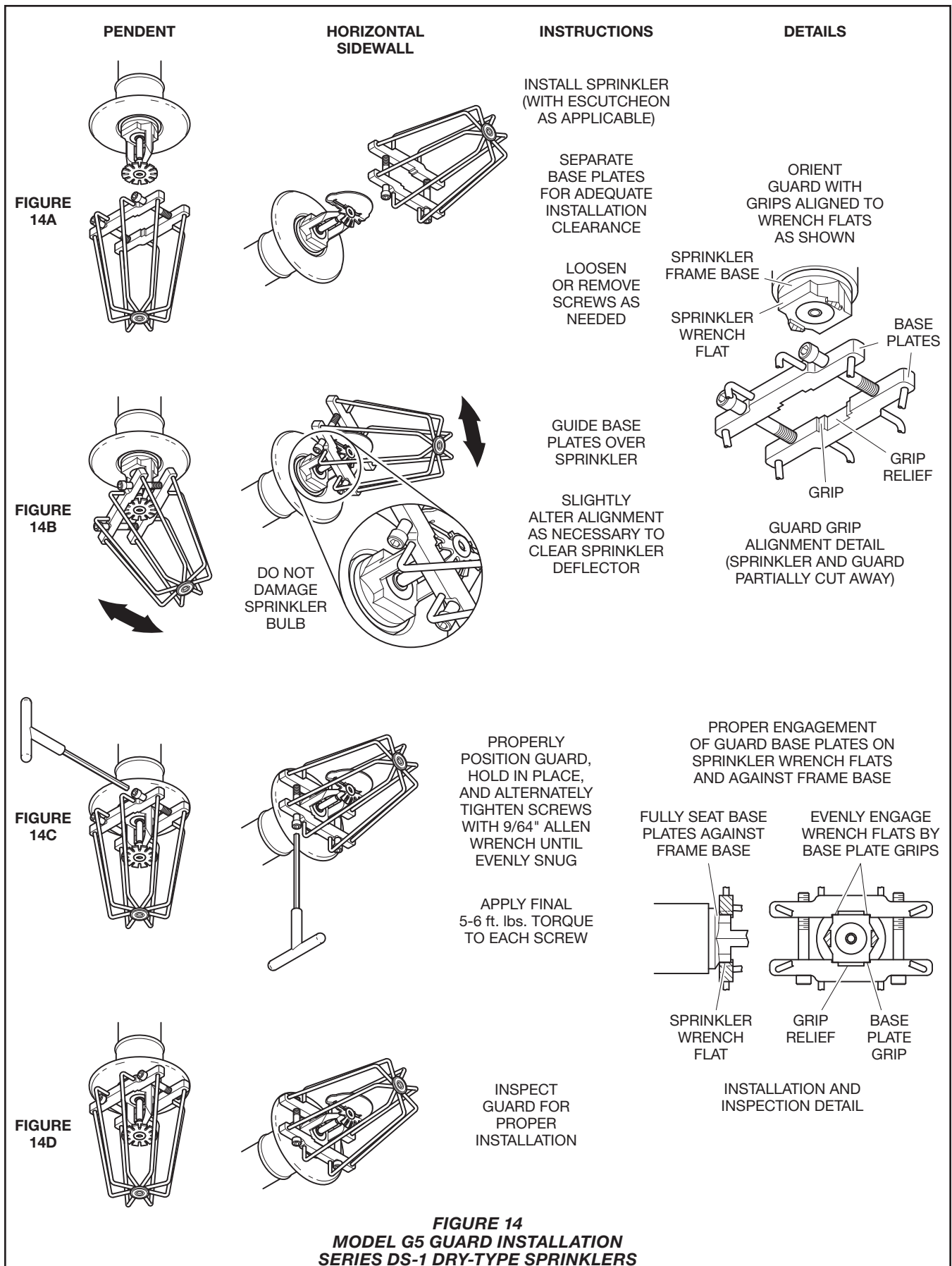

FIGURE 14
MODEL G5 GUARD INSTALLATION
SERIES DS-1 DRY-TYPE SPRINKLERS

Care and Maintenance

TYCO Model G1, G2, G4, and G5 Sprinkler Guards, G1/S1, G4/S3, and WSG-2 Sprinkler Guards with Shields, and S2, S4, S5, and WS-2 Sprinkler Shields do not require any regularly scheduled maintenance; however, proper installation of the Sprinkler Guards and Shields should be verified during the annual visual inspection of the sprinklers.

Before closing a fire protection system main control valve for maintenance work on the fire protection system that it controls, obtain permission to shut down the affected fire protection system from the proper authorities and notify all personnel who may be affected by this action.

The owner is responsible for the inspection, testing, and maintenance of their fire protection system and devices in compliance with this document, as well as with the applicable standards of the National Fire Protection Association (e.g., NFPA 25), in addition to the standards of any other authorities having jurisdiction. Contact the installing contractor or product manufacturer with any questions.

Automatic sprinkler systems are recommended to be inspected, tested, and maintained by a qualified Inspection Service in accordance with local requirements and/or national codes.

The owner must assure that the sprinklers are not used for hanging of any objects and that the sprinklers are only cleaned by means of gently dusting with a feather-duster. Otherwise, non-operation in the event of a fire or inadvertent operation may result.

Limited Warranty

For warranty terms and conditions, visit www.tyco-fire.com.

Ordering Procedure

Contact your local distributor for availability. When placing an order, indicate the full product name and Part Number (P/N).

Model G1 Sprinkler Guard

Specify: Model G1 Sprinkler Guard, (specify) finish, P/N (specify):

Red Painted56-938-1-001
Zinc Chromate56-938-9-001

Model G2 Sprinkler Guard

Specify: Model G2 Sprinkler Guard, (specify) finish, P/N (specify):

Red Painted56-000-1-087
Zinc Coated56-000-1-086

Model G4 Sprinkler Guard

Specify: Model G4 Sprinkler Guard, (specify) finish, P/N (specify):

Red Painted56-937-1-001
Zinc Chromate56-937-9-001

Model G5 Sprinkler Guard

Model G5 Sprinkler Guard is available only in Zinc Chromate finish.

Specify: Model G5 Sprinkler Guard, P/N 56-938-9-000

Model G1/S1 Sprinkler Guard with Shield

Specify: Model G1/S1 Sprinkler Guard with Shield, (specify) finish, P/N (specify):

Red Painted56-938-1-066
Zinc Chromate56-938-9-066

Model G4/S3 Sprinkler Guard with Shield

Specify: Model G4/S3 Sprinkler Guard with Shield, (specify) finish, P/N (specify):

Red Painted56-937-1-066
Zinc Chromate56-937-9-066

Model WSG-2 Sprinkler Guard with Shield

Specify: Model WSG-2 Sprinkler Guard with Shield, (specify) finish, P/N (specify):

Red Painted56-000-1-098
Zinc Coated56-000-1-097

Model S2 Sprinkler Shield

Model S2 Sprinkler Shield is available only in Plated Steel finish.

Includes S2 Shield and one O-Ring.

Specify: Model S2 Sprinkler Shield, (specify) Thread Size, P/N (specify):

1/2" NPT.56-070-9-332
3/4" NPT.56-070-9-342

Model S4 Sprinkler Shield

Includes S4 Shield, one O-Ring and one Speednut.

Specify: Model S4 Sprinkler Shield, (specify) finish, (specify) Thread Size, P/N (specify):

Plain Brass
1/2" NPT.56-952-1-001
3/4" NPT.56-152-1-001

Chrome Plated

1/2" NPT.56-951-9-001
3/4" NPT.56-152-9-001

Model S5 Sprinkler Shield

Model S5 Sprinkler Shield is available only in Brass finish.

Includes S5 Shield and two O-Rings.

Specify: Model S5 Sprinkler Shield, (specify) Thread Size, P/N (specify):

1/2" NPT.56-015-6-802
3/4" NPT.56-015-6-803

Model WS-2 Sprinkler Shield

Specify: Model WS-2 Sprinkler Shield, (specify) finish, (specify) Thread Size, P/N (specify):

Red Painted
1/2" NPT.56-000-1-081
3/4" NPT.56-000-1-083

Zinc Coated

1/2" NPT.56-000-1-080
3/4" NPT.56-000-1-082

Sprinkler Guard Installation Tool*

Specify: Sprinkler Guard Installation Tool, P/N 56-000-8-597

* For use with Model G1 and G4 guards and Model G1/S1 and G4/S3 guards with shields only. A Sprinkler Guard Installation Tool is included with orders in original carton quantities.