

FBB-150I, FBB-150JW FIRE ALARM BELL

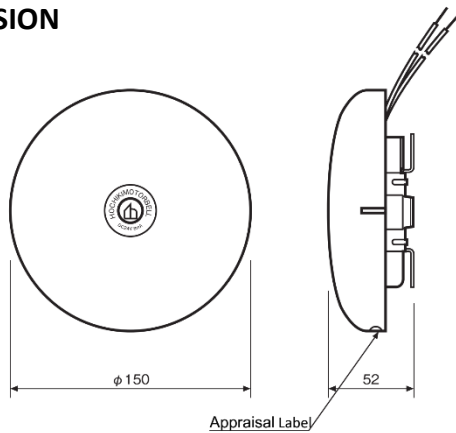

FBB-150I

DIMENSION



Unit: mm

Appraisal Label

SPECIFICATIONS

Type	Fire Alarm Bell (Indoor Use)
Model	FBB-150I
Alarm Current	8mA @24Vdc
Sound Level	Over 90dB (At Front 1m)
Operating Temp. Range	-20°C to 60°C
Material Gong	Aluminum Alloy
Installation Base	Steel Sheet t=1.2mm
Color	Munsell 7.5R3.6/12.8
Weight	Approx. 430g
Country of Origin	Japan
Approval	JFEII



FBB-150JW

DIMENSION

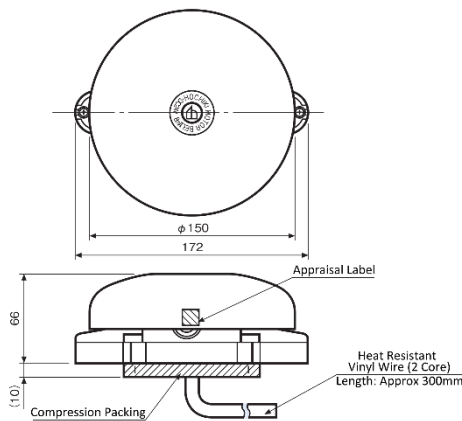

Unit: mm

SPECIFICATIONS

Type	Fire Alarm Bell (Outdoor Use)
Model	FBB-150JW
Alarm Current	8mA @24Vdc
Sound Level	Over 90dB (At Front 1m)
Operating Temp. Range	-20°C to 60°C
Material Gong	Aluminum Alloy
Installation Base	Aluminum Alloy
Color Gong	Munsell 7.5R3.6/12.8
Installation Base	Silver
Weight	Approx. 880g
Country of Origin	Japan
Approval	JFEII

Specifications subject to change without notice

09/2017

HOCHIKI ASIA PACIFIC PTE. LTD.

71 UBI Road 1 #07-40/41
 Oxley Bizhub Singapore 408732
 TEL : 65-6841-9728 FAX : 65-6841-9781
 URL : www.hochikisingapore.com

HEAD OFFICE

10-43 Kamiosaki 2-Chome. Shinagawa-Ku,
 Tokyo 141-8660 Japan
 TEL : 81-(3)-3444-4116 FAX : 81-(3)-3444-4167
 URL : www.hochiki.co.jp