

MEDIUM VELOCITY WATER SPRAY NOZZLE



TECHNICAL DATA

| | | |
|--|--|-------------|
| MODEL | MV-A & MV-AS Brass Material MV-B & MV-BS Stainless Steel Material MV-E Aluminium Bronze Material | |
| TYPE | MV-A, MV-B & MV-E are without strainer MV-AS & MV-BS are with strainer | |
| MAXIMUM WORKING PRESSURE | 12 Bar (175 PSI) | |
| END CONNECTION | ½" BSPT (½" NPT OPTIONAL) | |
| MATERIAL | Refer Table-I | |
| INCLUDED WATER SPRAY ANGLE FOR EACH K-FACTOR | 160°, 140°, 120°, 110°, 100°, 90°, 80° & 65° | |
| K FACTOR | MV-A/MV-B & MV-E | MV-AS/MV-BS |
| | Metric (US) | Metric (US) |
| | K-18 (1.26) | K-18 (1.26) |
| | K-22 (1.54) | K-22 (1.54) |
| | K-26 (1.8) | K-26 (1.8) |
| | K-30 (2.10) | K-30 (2.10) |
| | K-35 (2.45) | K-35 (2.45) |
| | K-41 (2.87) | K-41 (2.87) |
| | K-51 (3.57) | |
| | K-64 (4.48) | |
| | K-79 (5.53) | |
| | K-91 (6.37) | |
| | K-102 (7.14) | |
| FINISH | MV-A & MV-AS Natural Brass finish, Nickel-Chrome plated, Electroless Nickel plated, Epoxy powder coated. MV-B, MV-BS & MV-E Natural finish | |
| APPROVALS | UL Listed, FM Approved & LRS-Lloyd's Register Approved Blow-off Plug- FM Approved For Approval data refer Table-II | |
| ORDERING INFORMATION | Specify K-Factor, spray angle, finish, model and end connection | |



DESCRIPTION

The HD® Medium Velocity Water Spray Nozzles are open type (non-automatic) nozzles, designed for directional spray application in fixed fire protection system.

Medium velocity water spray nozzle has an external deflector, which discharges water in a directional cone shaped pattern of small droplet size. The water is uniformly distributed over the surface to be protected.

MV Nozzles are effectively designed to apply water to exposed vertical, horizontal, curved and irregular shaped surfaces to allow cooling to prevent excessive absorption of heat from external fire and avoid structural damage or spread of fire. In some application nozzles may be installed to control or extinguish the fire depending on water design density as per applicable codes. The nozzle is used in deluge water spray system for special hazard fire protection application.

As the design and intent of specific water spray system may vary considerably, MV nozzle is made available in several combinations of orifice sizes (K-factors) and spray angles.

The minimum desirable pressure to achieve a reasonable spray pattern is 1.4 Kg./Sq.cm. The water distribution pattern as shown in the graph in following pages is at an average pressure of 2.0 Kg/Sq.cm. The change in pressure between 1.4 to 3.5 Kg./sq.cm. does not affect considerable change in spray angle.

The spray pattern shown is with indoor application. System designer must consider wind velocity while designing the system for outdoor application. Field obstruction if any affecting the spray pattern of the nozzle must also be considered. The nozzle may be oriented to any position as deemed necessary to cover the hazard.

The Blow-off plugs can be used to prevent the depositing of foreign materials in the water way of the nozzles, which could interfere with discharge of the spray nozzle. Blow-off plugs are optional and are FM Approved. Blow-off Plugs have identification mark with respect to K factor. For example, Blow off plug for nozzle having K-factor 22 will have identification mark of 22. Minimum operating pressure for nozzle having Blow-off plug is 1.4 Kg./Sq.cm (20 PSI).

The main pipeline strainer as per NFPA-15 is required for system utilizing nozzle orifice diameter less than 9.5mm (3/8 inch), i.e. MV Nozzle having K-factor 41 and less, and also for the system water likely to contain obstructive materials.

INSTALLATION & MAINTENANCE

The spray nozzle must be handled with due care. For best results, the storage as well as any further shipment shall be made in original packing only.

Nozzle which is visibly damaged should not be installed. Use Teflon tape or soft thread sealant on male thread of the nozzle.

The nozzles must be hand tightened into the fitting. After hand tightening use Nozzle Wrench-NW-M for wrench tightening in to nozzle fittings. Excessive tightening torque may result into serious damage to nozzle arms and the deflector, which may affect spray pattern of the nozzle and its performance.

It is recommended that water spray system be inspected regularly by authorised technical personnel.

The nozzle must be checked for atmospheric effects, external and internal obstruction, blockage if any. The system must be operated with optimum water flow at least twice in a year or as per the provisions of NFPA or local authority having jurisdiction.

It is recommended to design water spray system as per guidelines of NFPA15 and/or AHJ.

The owner is solely responsible for maintaining the water spray system and the components there in so that it performs properly when required.

MODEL MV-A, MV-B & MV-E

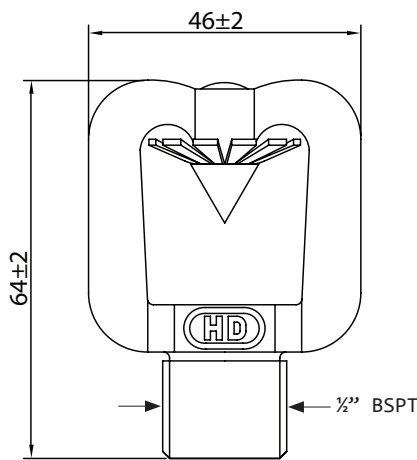

MODEL MV-AS, & MV-BS

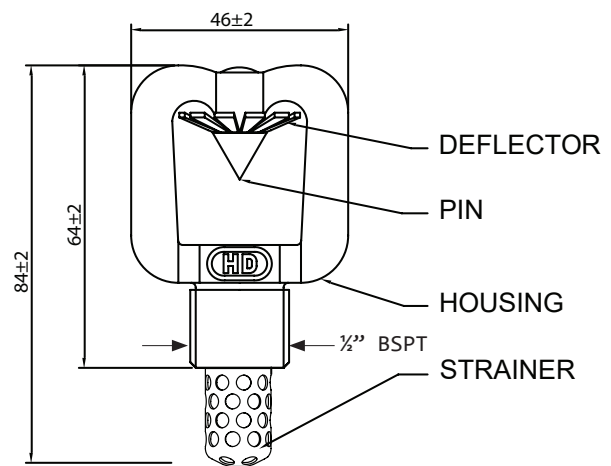

Nozzles with Blow-off Plug

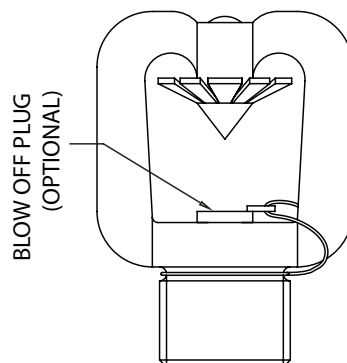

TABLE - I : MATERIAL OF CONSTRUCTION

| COMPONENT | MODEL MV-A & MV-AS | MODEL MV-B & MV-BS | | MODEL MV-E |
|--------------|---|--------------------------------------|---------------------------------------|---|
| | | STANDARD | OPTIONAL | |
| HOUSING | BRASS, IS:291 GR. -1 (EQUIVALENT TO ASTM B21) | ASTM A351-CF8M (STAINLESS STEEL 316) | ASTM A351 CF3M (STAINLESS STEEL 316L) | ALUMINIUM BRONZE IS:305-AB1 (EQUIVALENT TO ASTM B148) |
| PIN | BRASS IS:291. GR. -1 (EQUIVALENT TO ASTM B21) | ASTM-A479 GR 31803 | ASTM A479 TYP. 316L | PH.BRONZE IS:7811 (EQUIVALENT TO ASTM B139) |
| DEFLECTOR | BRASS IS:2768 (EQUIVALENT TO ASTM B36) | ASTM A240 GR 2205 | ASTM A240 TYP. 316L | PH.BRONZE IS:7814-GR-II (EQUIVALENT TO ASTM B103) |
| STRAINER | COPPER (FOR MV-AS) | STAINLESS STEEL 316 (FOR MV-BS) | STAINLESS STEEL 316L | - |
| BLOW-OFF CAP | ELASTOMER | ELASTOMER | ELASTOMER | ELASTOMER |

Note: Equivalent specification is indicative only.

TABLE - II : APPROVAL DATA

| K-FACTOR | SPRAY ANGLE | MODEL & APPROVALS | | | | | | | | | | | | | | |
|------------------------|---|------------------------------|----|-----|----------------------------|----|-----|---------------------------------------|----|-----|-------------------------------------|----|-----|-----------------------|----|-----|
| | | MV-A BRASS, WITHOUT STRAINER | | | MV-AS BRASS, WITH STRAINER | | | MV-B STAINLESS STEEL WITHOUT STRAINER | | | MV-BS STAINLESS STEEL WITH STRAINER | | | MV-E ALUMINIUM BRONZE | | |
| | | UL | FM | LRS | UL | FM | LRS | UL | FM | LRS | UL | FM | LRS | UL | FM | LRS |
| K- 18, 22, 30, 35, 41 | 65°, 80°, 90°, 100°, 110°, 120°, 140° | √ | √ | √ | √ | √ | √ | √ | √ | √ | √ | √ | √ | √ | √ | √ |
| K- 18, 22, 30, 35, 41 | 160° | √ | -- | -- | √ | -- | -- | √ | -- | -- | √ | -- | -- | √ | -- | -- |
| K- 26 | 65°, 80°, 90°, 100°, 110°, 120°, 140°, 160° | √ | -- | -- | √ | -- | -- | √ | -- | -- | √ | -- | -- | √ | -- | -- |
| K- 51, 64, 79, 91, 102 | 65°, 80°, 90°, 100°, 110°, 120°, 140° | √ | √ | √ | -- | -- | -- | √ | √ | √ | -- | -- | -- | √ | √ | √ |

DISCHARGE CHARACTERISTICS

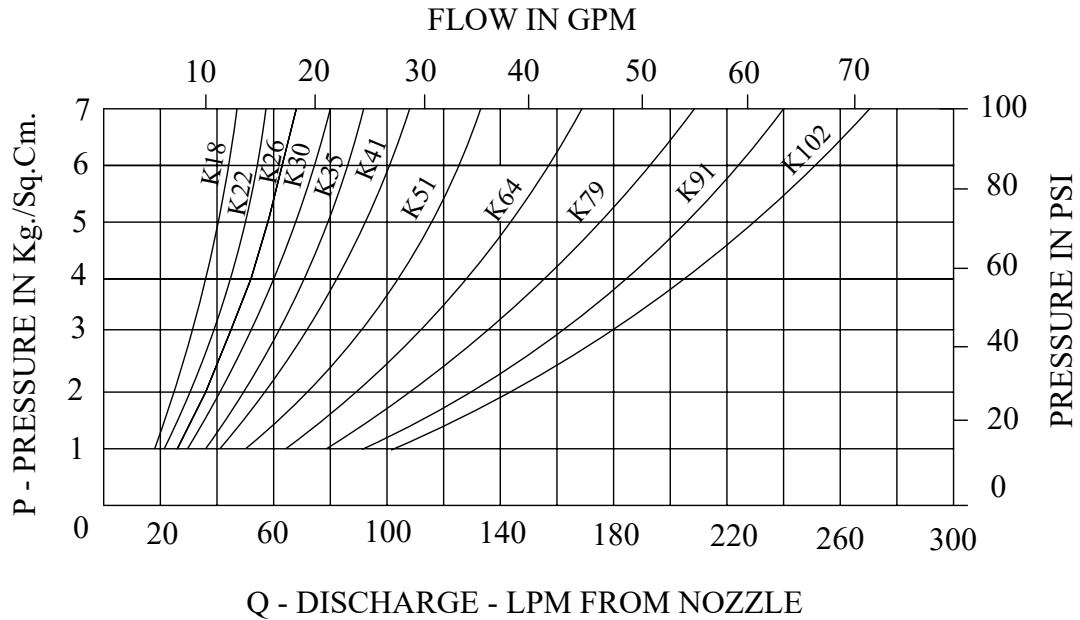

$Q = K \sqrt{P}$ where P is supply pressure in Kg/sq.cm., K= nozzle constant (K-factor) in metric
 US K factor = Metric K factor MK ÷ 14.2745

SPRAY PATTERN

SPRAY ANGLE 65°

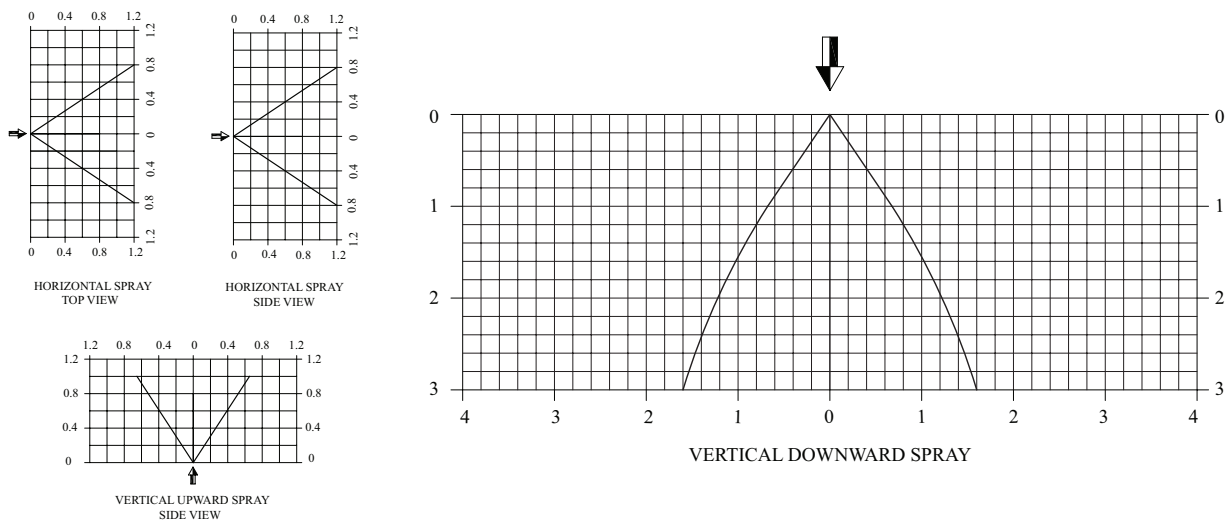

ALL DIMENSIONS ARE IN METERS

SPRAY PATTERN

SPRAY ANGLE 80°

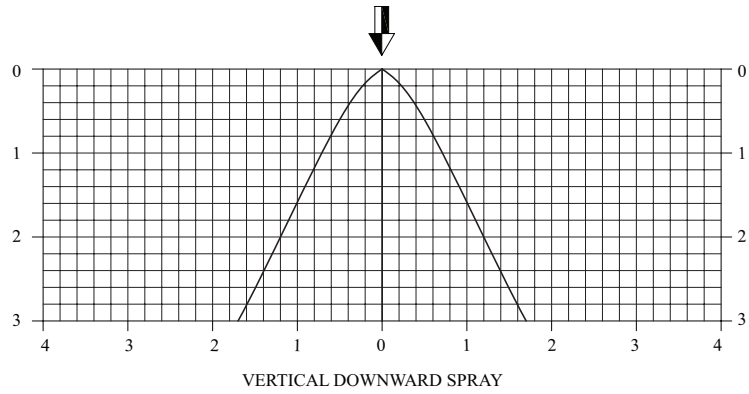
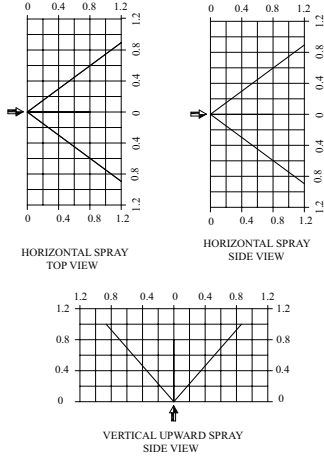

SPRAY ANGLE 90°

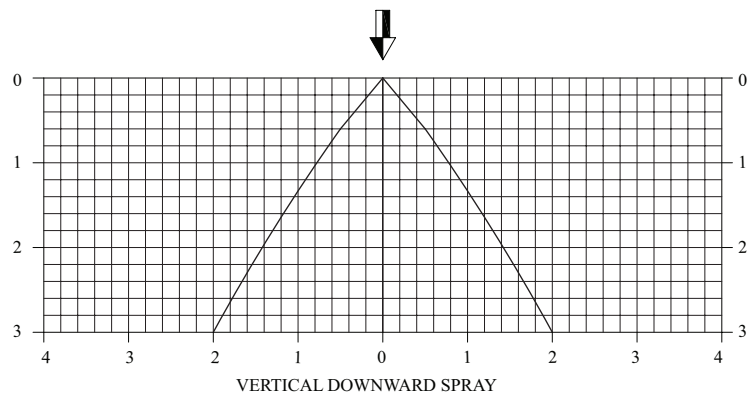
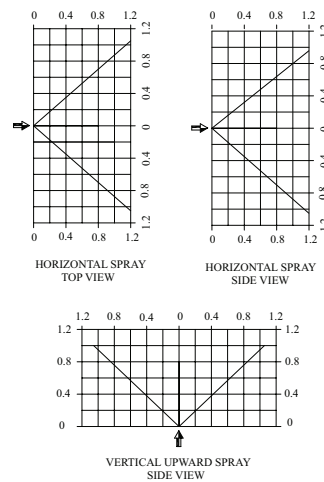

SPRAY ANGLE 100°

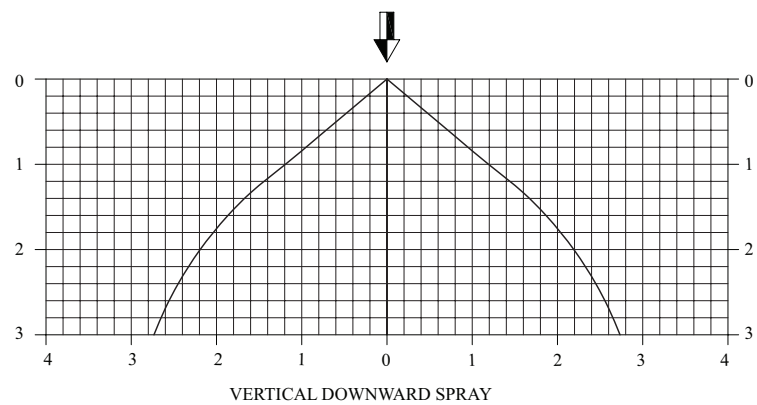
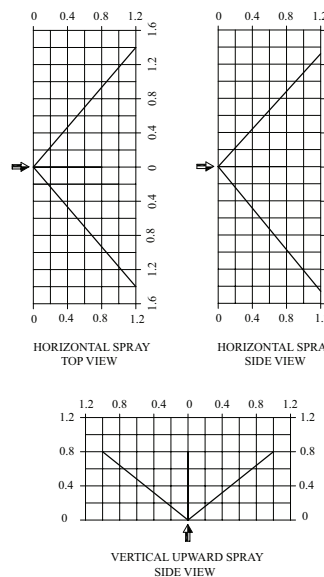

ALL DIMENSIONS ARE IN METERS

SPRAY PATTERN

SPRAY ANGLE 110°

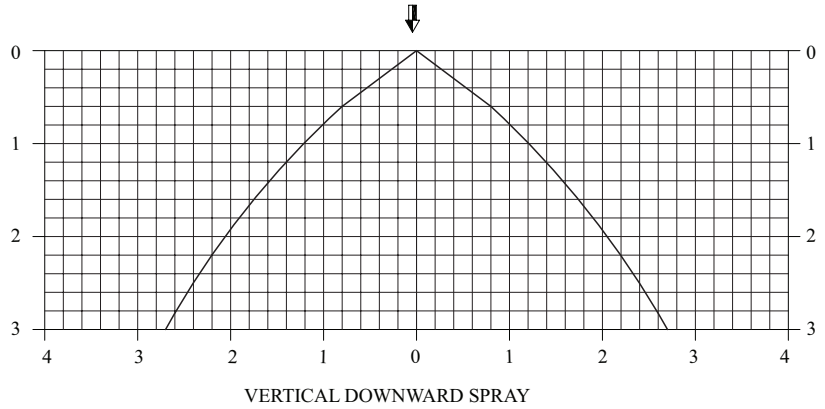
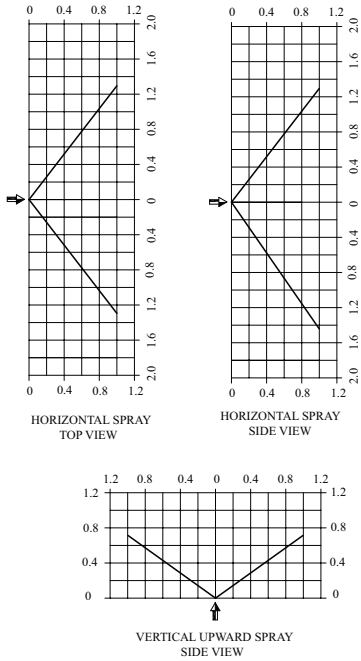

SPRAY ANGLE 120°

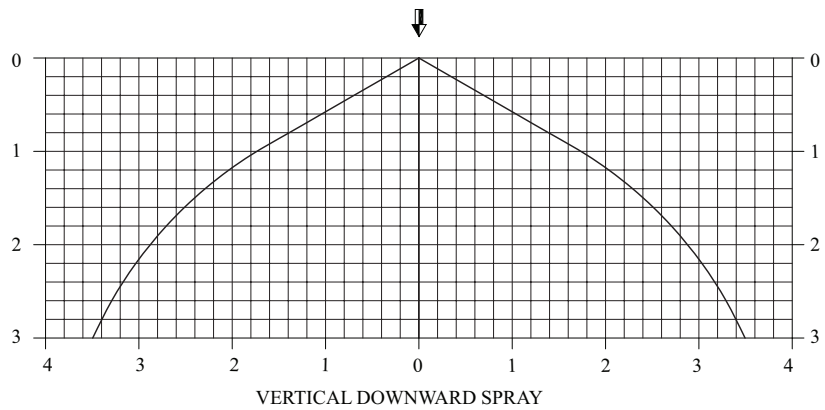
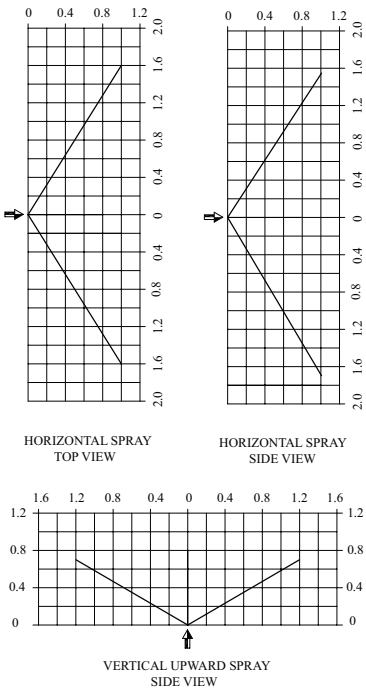

ALL DIMENSIONS ARE IN METERS

SPRAY PATTERN

SPRAY ANGLE 140°

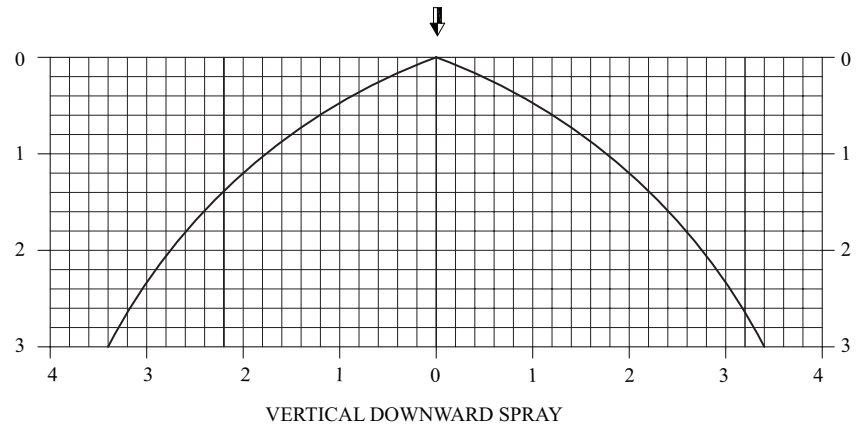
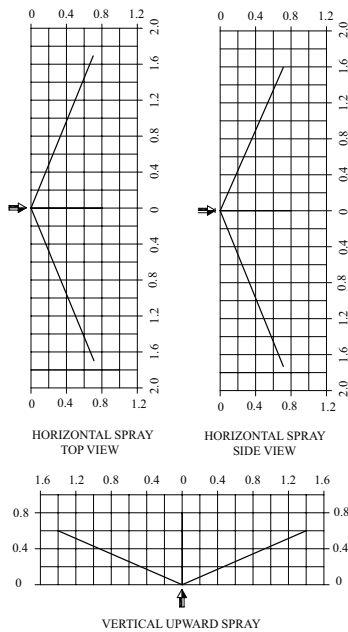

SPRAY ANGLE 160°

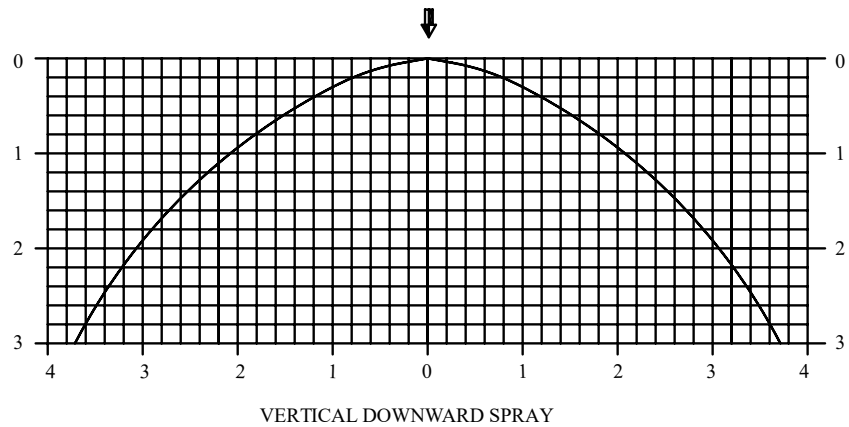
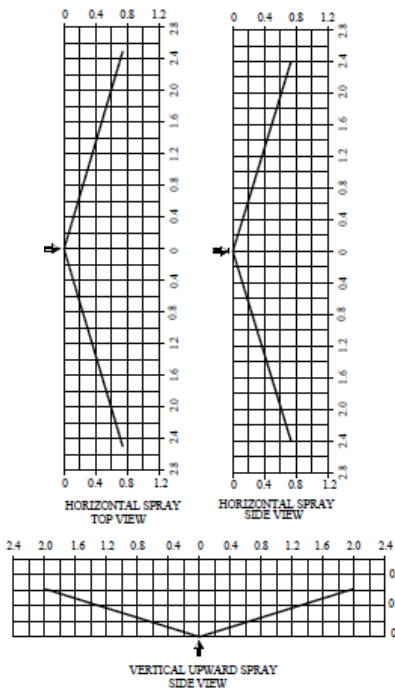

ALL DIMENSIONS ARE IN METERS

Note :

- 1) The design spray patterns given in graphs are included spray angle of 65 Deg. to 160 Deg. at nozzle inlet pressure of 1.4 to 4.1 Bar. When the nozzle pressure above 4.1 Bar is applied, the coverage area will decrease because the spray pattern tends to draw inward at higher pressure. Consult HD Technical Services for pressure upto 12.1 Bar.
- 2) The spray data are obtained from the test in still air.

MV NOZZLE WRENCH MODEL NW-M

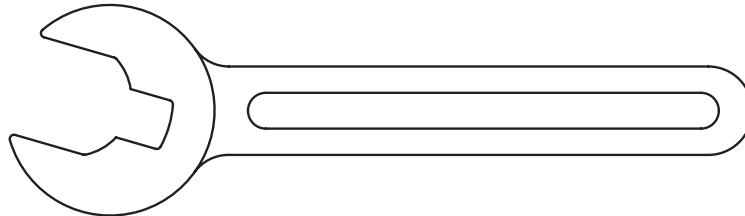

LIMITED WARRANTY

HD FIRE PROTECT PVT. LTD. hereby referred to as HD FIRE warrants to the original purchaser of the fire protection products manufactured by HD FIRE and to any other person to whom such equipment is transferred, that such products will be free from defect in material and workmanship under normal use and care, for two (2) years from the date of shipment by HD FIRE. Products or Components supplied or used by HD FIRE, but manufactured by others, are warranted only to the extent of the manufacturer's warranty. No warranty is given for product or components which have been subject to misuse, improper installation, corrosion, unauthorized repair, alteration or un-maintained. HD FIRE shall not be responsible for system design errors or improper installation or inaccurate or incomplete information supplied by buyer or buyer's representatives. HD FIRE will repair or replace defective material free of charge, which is returned to our factory, transportation charge prepaid, provided after our inspection the material is found to have been defective at the time of initial shipment from our works. HD FIRE shall not be liable for any incidental or consequential loss, damage or expense arising directly or indirectly from the use of the product including damages for injury to person, damages to property and penalties resulting from any products and components manufactured by HD FIRE. HD FIRE shall not be liable for any damages or labour charges or expense in making repair or adjustment to the product. HD FIRE shall not be liable for any damages or charges sustained in the adaptation or use of its engineering data & services. In no event shall HD Fire's product liability exceed an amount equal to the sale price. The foregoing warranty is exclusive and in lieu of all other warranties and representation whether expressed, implied, oral or written, including but not limited to, any implied warranties or merchantability or fitness for a particular purpose. All such other warranties and representations are hereby cancelled.

NOTICE :

The equipment presented in this bulletin is to be installed in accordance with the latest publication standards of NFPA or other similar organisations and also with the provision of government codes or ordinances wherever applicable.

The information provided by us is to the best of our knowledge and belief, and consist of general guidelines only. Site handling and installation control is not in our scope. Hence we give no guarantee for result and take no liability for damages, loss or penalties whatsoever, resulting from our suggestion, information, recommendation or damages due to our product.

Product development is a continuous programme of HD FIRE PROTECT PVT. LTD. and hence the right to modify any specification without prior notice is reserved with the company.



HD FIRE PROTECT PVT. LTD.
Protecting What Matters Most to You

D-6/2, ROAD NO. 34, WAGLE INDUSTRIAL ESTATE, THANE 400 604, INDIA.

• TEL: + (91) 22 2158 2600

• FAX: +(91) 22 2158 2602

• EMAIL: info@hdfire.com

• WEB: www.hdfire.com