

300 PSI CWP Iron Body Gate Valves

Fire Protection Valve • Outside Screw and Yoke • **Resilient Wedge** • Epoxy Coated Interior/Exterior • Pre-Grooved Stem for Supervisory Switch • Drilled, Tapped and Plugged at Boss Location A**

300 PSI/20.6 Bar Non-Shock Cold Working Pressure

UL/ULC LISTED† • FM APPROVED • CERTIFIED LEAD-FREE* BY IAPMO R&T TO NSF/ANSI 372



NSF/ANSI 372

LOW-LEAD



F-607-RWS
Flanged

MATERIAL LIST

PART	SPECIFICATION
1 Valve Body	Ductile Iron ASTM A536
2 Resilient Wedge	Ductile Iron ASTM A536/EPDM ASTM D2000
3 Wedge Nut	ASTM B584 UNS C83600
4 Dowel Pin	ASTM A276 SS304
5 Stem Back Seat O-Ring	EPDM ASTM D2000
6 Bonnet Gasket	EPDM ASTM D2000
7 Bonnet	Ductile Iron ASTM A536
8 Stem Packing	EPDM ASTM D2000
9 Threaded Rod	ASTM A276 SS304
10 Gland Bushing	ASTM B584 UNS C83600
11 Gland	Ductile Iron ASTM A536
12 Gland Nut	ASTM B148 C95200 Aluminum Bronze
13 Yoke	Ductile Iron ASTM A536
14 Yoke Bushing	ASTM B150 C61400
15 Flat Point Set Screw	ASTM F912M
16 Yoke Bushing Retainer	Cast Iron ASTM A126 Class B
17 Handwheel	Ductile Iron ASTM A536
18 Handwheel Nut	Carbon Steel Zinc Plated
19 Stem	Stainless Steel 304
20 Bonnet Screw	Corrosion-resistant Steel
21 NPT Pipe Plug	Steel ASME B16.14
22 UL/FM Label (not shown)	Aluminium
23 Yoke Nut	ASTM B148 C95200 Aluminum Bronze
24 Drive Screw Label (not shown)	Stainless Steel 304

Coating — Electrostatically applied fusion-bonded epoxy 8-20 mil. inside and outside. Meets or exceeds AWWA C550.

**Drilled, tapped and plugged at Position A with 1/2" valve sizes 2 1/2"-4", 3/4" on 6"-8", 1" on 10"-12".

† Compliance with the Standard for Gate Valves for Fire Protection Service, UL 262, and the Canadian Requirements, ULC/ORD-C262.

NOTE: Flanged valve is consistent with ANSI B16.1 Class 125.

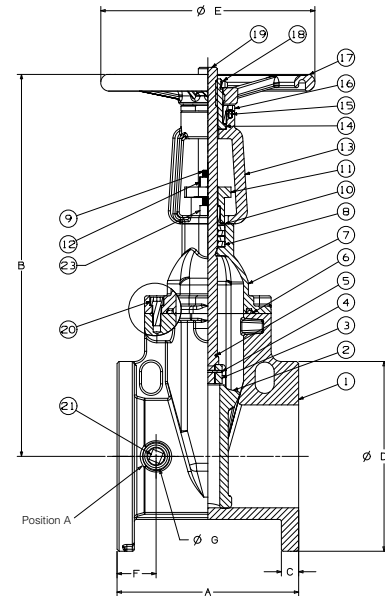

F-607-RWS
Flg x Flg

DIMENSIONS—WEIGHTS—QUANTITIES

Size	Dimensions														Bolt Circle	Flange Holes	Turns To Open	Weight					
	A		B Open		B Closed		C		D		E		F					G		Lbs.	Kg.		
In. mm.	In. mm.	In. mm.	In. mm.	In. mm.	In. mm.	In. mm.	In. mm.	In. mm.	In. mm.	In. mm.	In. mm.	In. mm.	In. mm.	In. mm.	In. mm.	In. mm.							
2 1/2	65	7.5	190	17.8	453	14.9	378	0.69	17.5	7.0	178	7.9	200	1.50	38	1.42	36	5.50	140	4	6.3	39	18
3	80	8.0	203	19.7	500	15.9	405	0.75	19.0	7.5	191	7.9	200	1.73	44	1.42	36	6.00	152	4	10.0	44	20
4	100	9.0	229	21.0	534	16.6	422	0.94	24.0	9.0	229	10.2	260	2.13	54	1.42	36	7.50	191	8	10.0	72	33
6	150	10.5	267	29.3	744	22.9	581	1.00	25.4	11.0	279	12.4	315	2.24	57	1.54	39	9.50	241	8	15.0	117	53
8	200	11.5	292	37.0	939	28.5	724	1.13	28.6	13.5	343	14.8	375	2.48	63	1.54	39	11.75	298	8	16.7	198	90
10	250	13.0	330	44.8	1139	34.5	877	1.19	30.2	16.0	406	16.4	416	3.15	80	1.82	46	14.25	362	12	20.8	374	170
12	300	14.0	356	52.2	1326	39.9	1014	1.25	31.8	19.0	483	17.5	445	2.91	74	1.82	46	17.00	432	12	25.0	493	224
14*	350	15.0	375	62.2	1580	50.0	1270	1.38	35.0	21.0	533	19.7	500	2.95	75	3.20	81	18.75	476	12	43.8	620	284
16*	400	16.0	400	65.9	1674	50.4	1280	1.44	37.0	23.5	597	19.7	500	3.03	77	3.20	81	21.25	540	16	50.0	816	370

*14 and 16" valves 250 PSI CWP

FREEZING WEATHER PRECAUTION: Subsequent to testing a piping system, gate valve should be in an open position to allow complete drainage.

*Weighted average lead content ≤ 0.25%