



# PORTABLE FIRE FIGHTING PUMP P509RS

SUPER BALLCOCK VALVE  
OPTIONAL



A NEW TYPE VALVE OF ONE-TOUCH OPERATION.  
THIS PROMOTES FURTHER IMPROVEMENT IN EASY AND EFFICIENCY OF OPERATION.



## 55PS

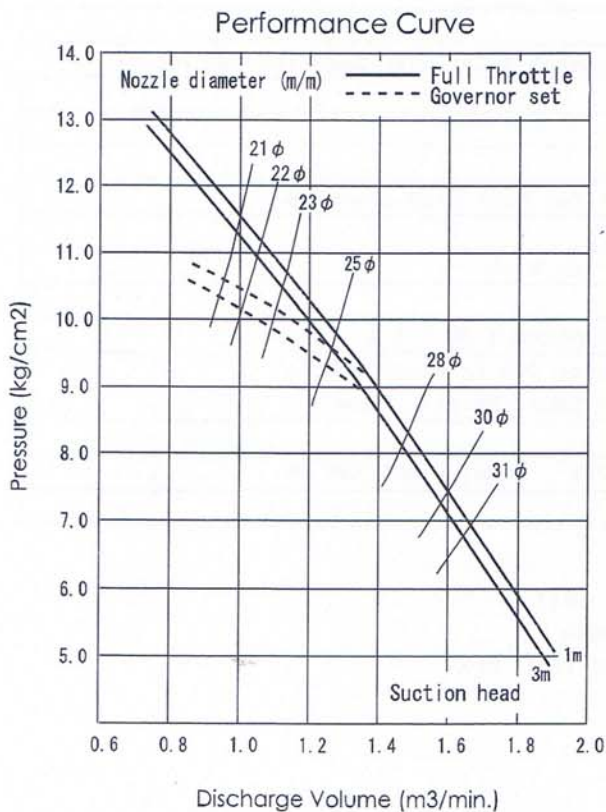

Material of Impeller & Casing is applied rust proof HIGH STRENGTH LIGHT ALLOY for extra long life.

Three way starting method for emergency use;  
ELECTRIC CELL STARTER  
RECOIL STARTER  
ROPE STARTER.

For accurate starting and quick discharge, operation procedures are indicated by big figures and operation panel is illuminated by panel light for easy operation at night.



**FUJI ROBIN INDUSTRIES LTD.**  
**NUMAZU, JAPAN**

## SPECIFICATIONS

### P509R S/M

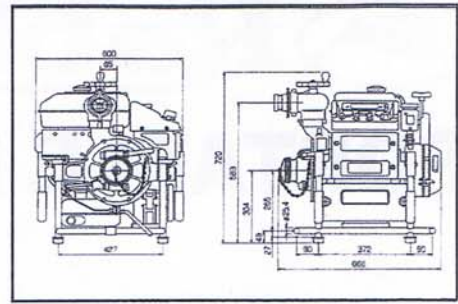

MODEL	RABBIT P509R S/M
Type	Light weight Portable Fire Pump
Dimensions	L. 666mm x W. 637mm x H. 720mm
Dry weight	About 88kgs. (S)/78kgs. (M)

#### PUMP

Model Name	P509
Type	High Pressure One Stage Turbine Pump
Inlet dia.	nominal 90mm. (3.5in.) or 75mm. (3in.)
Outlet dia.	nominal 65mm. (2.5in.)
Water discharge Performance	
Rated Pressure	7.0kg/cm <sup>2</sup> with nozzle dia. 30.0mm
Rated Discharge Volume	Over 1.55m <sup>3</sup> /min.
High Pressure	10.0kg/cm <sup>2</sup> with nozzle dia. 23.0mm
Discharge Volume at High Pressure	Over 1.1m <sup>3</sup> /min.
Rated Revolution	5,100r. p. m. (Governor set)
Pump Chamber Seal	Mechanical Unit Seal
Vacuum Pump	4-blade eccentric rotary type with Strainer
Vacuum	Water suction 9meter (Over 640mm Hg)
Lubrication	Automatic lubrication (SAE #30. in winter #20)
Option	Two way discharge port

#### ENGINE

Model	EP58
Type	Water cooled Horizontal 2-Cylinder Gasoline Engine
No. of Cylinder - Bore x Stroke	2 - 76 x 70 (mm)
Total Displacement	635 cc.
Maximum Output	55PS
Fuel consumption	290 g/PS.h or 15 liter/hour/high pressure
Fuel tank capacity	about 12 liter
Ignition	(CDI) Solid state ignition
Plug	NGK B7HS
Fuel type	Lubricant gasoline mixed ( 30 : 1 )
Starting	(S) Cell starter type (Cell, Recoil, Rope) (M) Manual starter type (Recoil, Rope)
Speed control	Eccentric gravity
Light	Search light 12V 25W Panel Light 12V 8W
Battery	12V 30AH (S)

#### STANDARD ACCESSORIES



1. SEARCH LIGHT UNIT
2. BATTERY CHARGER
3. TOOL KIT WITH TOOL BOX
4. JOINT
5. FUEL MIXER
6. OIL CUP
7. BULB
8. SPARK PLUG
9. FUSE
10. INSTRUCTION MANUAL

All above specifications are subject to change without notice.