

Siren With Strobe

Siren With LED Strobe Alarm

U-811



Features

- Sound & flash alarm
- Loud siren to alert others of emergency.
- Bright LED (red color) strobe for visual warning and efficient energy consumption.
- Fits european surface box type.

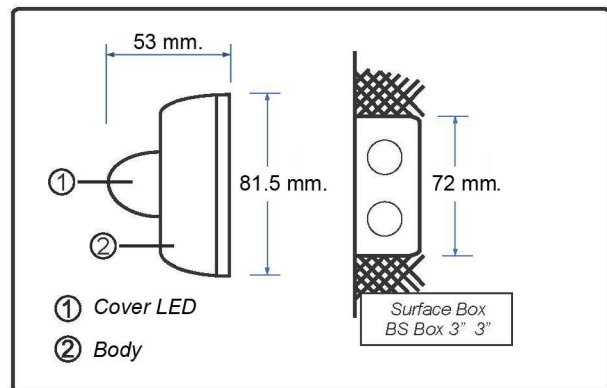

Specification

Model / Product	U-811 Siren With Strobe Alarm		
Input voltage	12 VDC	/	24 VDC
Alarm	10 mA at 12 VDC	/	20 mA at 24 VDC
Strobe	6 pcs super bright LED (red color)		
Sound output	95 ± 5dB at 1M 12 VDC	/	100 ± 5dB at 1M 24 VDC
Cover LED / Body	Red Color		
Siren tone	SWEEP, BELL WHISTLE		
Operating Temperature	- 10°C-50°C		
Weight / Paper Box	80g / 10g		
Dimention (W x H x D)	81.5 x 81.5 x 53 mm.		