

YS-70300

- Flange dimensions: BS4504 PN16
- Maximum working pressure: 16 bar
- Operating temperature: -10°C to 120°C
- Test pressure (Hydraulic): 24 bar

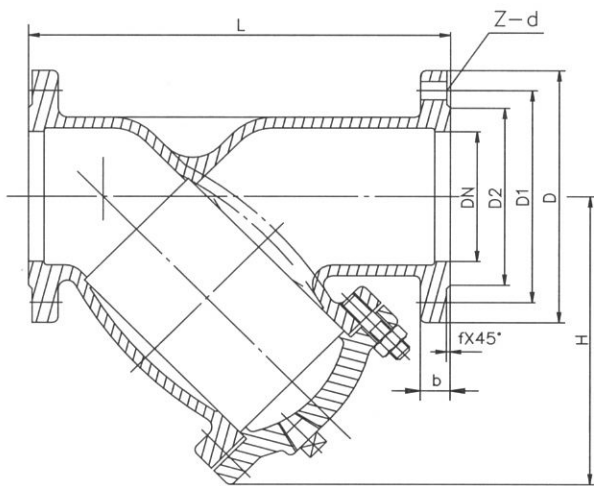

MATERIAL SPECIFICATION

Part Name	Material
1. Strainer Body	Cast Iron
2. Screen	Stainless Steel
3. Strainer Cover	Cast Iron
4. Bonnet Gasket	Graphite + Steel Plate
5. Plug	Malleable Cast Iron
6. Bolt	Steel
7. Nut	Steel

DIMENSIONS - WEIGHTS

SIZE INC.	DIMENSIONS								WEIGHT KG.
	L	D	D1	D2	b	z-d	f	H	
	MM.	MM.	MM.	MM.	MM.	MM.	MM.	MM.	
2	220	165	125	99	20	4-19	3	182	13
2.5	270	185	145	118	20	4-19	3	188	17
3	290	200	160	132	22	8-19	3	195	20
4	350	220	180	156	24	8-19	3	246	33
5	390	250	210	184	26	8-19	3	302	51
6	440	285	240	211	26	8-23	3	320.7	67
8	540	340	295	266	30	12-23	3	397.5	103
10	660	405	355	319	32	12-28	3	483	184
12	720	460	410	370	32	12-28	4	560	286