



SHILLA FIRE

WATER MONITOR JUMBO NOZZLE DATA SHEET

REV

1	JOB NO.	-	ITEM NO.	-
2	PROJECT		SERVICE	WATER SYSTEM
3	CLIENT		NO. REQ'D	
4	LOCATION		INSTALLATION	<input type="checkbox"/> INDOOR <input checked="" type="checkbox"/> OUTDOOR

- 6 TYPE : MANUAL OPERATION & FOG / STRAIGHT STREAM TYPE
- 7
- 8 MODEL NO. : SL-16JNW
- 9 CONNECTION : INLET - NH3" FEMALE
- 11 WORKING PRES. : 12.5 barg
- 12 TEST PRESSURE : MAX. 15 barg
- 13 MATERIAL : BODY - AL. ALLOY
- 14 : DEFLECTOR - AL. ALLOY
- 15 : HANDLE - PLASTIC (NYLON)
- 16 SURFACE : HARD ANODIZED COAT. (BLACK)
- 17 FLOW RATE : 1000 GPM at. 10 barg
- 18 Shooting Range: 65 Meter (Straight) / at. 7.0 barg
- 19 SPRAY ANGLE : MAX. 110 DEG.
- 20 LENGTH : 201.5 mm
- 21 WEIGHT : Approx. kg

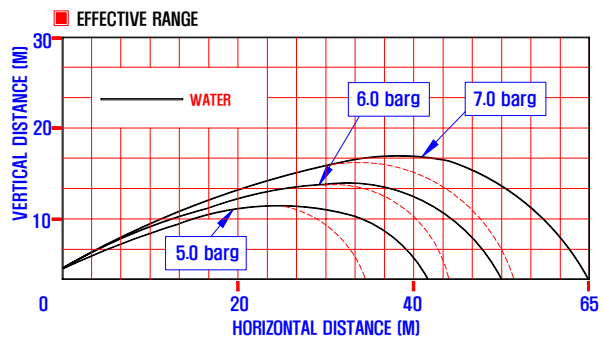
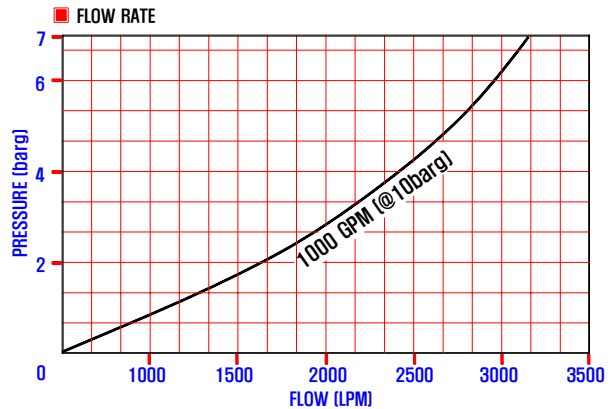
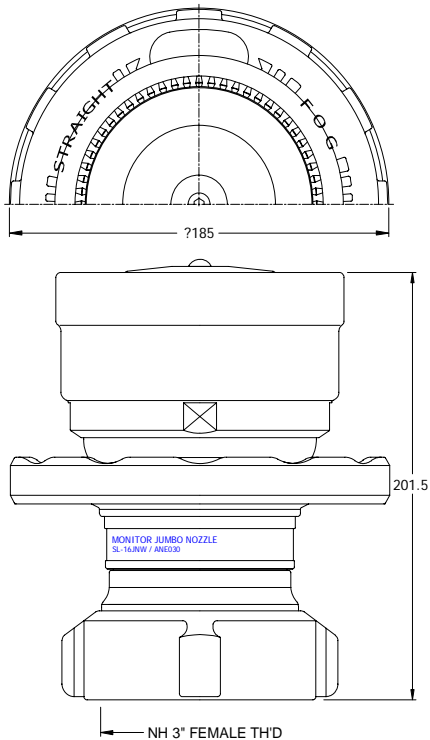

REV.	DATE	PREP. BY	CHK'D BY	APP'D BY	DESCRIPTION
0	AUG.25.'06	J.W.YANG	H.J.PARK		FOR QUOTATION
1					
2					