

AUTOMATIC SPRINKLER

BRAND NAME : **TYCO**
COUNTRY : **U.S.A.**
MODEL : **ESFR-34**
OPERATING TYPE : **FUSIBLE LINK TYPE**
RESPONSE : **EARLY SUPPRESSION FAST RESPONSE**
CONNECTION : **1.1/4" NPT.**
APPROVED : **FM APPROVED**

MATERIAL OF CONSTRUCTION

FRAME : **BRASS**
FINISHED : **NATURAL BRASS**
DEFLECTOR : **BRONZE**

ENGINEERING DATA

K-FACTOR : **33.6**
STYLE : **PENDENT**
TEMPERATURE RATING : **O - 165'F / 74'C**
O - 212'F / 100'C

Model ESFR-34 33.6 K-factor Pendent Sprinklers Early Suppression, Fast Response

General Description

TYCO Model ESFR-34 Pendent Sprinklers are Early Suppression, Fast Response Sprinklers having a nominal K-factor of 33.6 (See Figure 1). They are suppression-mode sprinklers that are especially advantageous as a means of eliminating the use of in-rack sprinklers when protecting high-piled storage.

The Model ESFR-34 Sprinklers are primarily used for ceiling-only sprinkler protection of (but not limited to) the following storage applications:

- most encapsulated or non-encapsulated common materials including cartoned, unexpanded plastics
- uncartoned (exposed) expanded plastics in accordance with FM Global standards
- some storage arrangements of rubber tires, roll paper, flammable liquids, and aerosols

For more specific criteria, refer to Table B as well as the applicable design standard.

The Model ESFR-34 can protect a storage arrangement of 50 ft (15,2 m) with a ceiling height of 55 ft (16,8 m) without requiring in-rack sprinklers. In addition, it can be installed with a maximum centerline of thermal sensing element-to-ceiling distance of 17 in. (432 mm).

IMPORTANT

Refer to Technical Data Sheet TFP2300 for warnings pertaining to regulatory and health information.

Always refer to Technical Data Sheet TFP700 for the "INSTALLER WARNING" that provides cautions with respect to handling and installation of sprinkler systems and components. Improper handling and installation can permanently damage a sprinkler system or its components and cause the sprinkler to fail to operate in a fire situation or cause it to operate prematurely.

NOTICE

The Model ESFR-34 Sprinklers described herein must be installed and maintained in compliance with this document, as well as with the applicable standards of FM Global, in addition to the standards of any authorities having jurisdiction. Failure to do so may impair the performance of these devices.

The owner is responsible for maintaining their fire protection system and devices in proper operating condition. Contact the installing contractor or product manufacturer with any questions.

In all cases, the appropriate FM installation standard, or other applicable standard, must be referenced to ensure applicability and to obtain complete installation guidelines. The general guidelines in this technical data sheet are not intended to provide complete installation criteria.

Sprinkler Identification Number

See Table A for sprinkler identification number.



Technical Data

Approvals
FM Approved

Finish
Natural Brass

Physical Characteristics

Frame	Brass
Deflector	Bronze
Compression Screw	Stainless Steel
Hook	MONEL
Strut	MONEL
Link Assembly	Solder, Nickel
Button	Stainless Steel
Sealing Assembly	Beryllium Nickel w/TEFLON

Additional Technical Data

See Table A for additional technical data.

Operation

The fusible link assembly is comprised of two link halves that are joined together by a thin layer of solder. When the rated temperature is reached, the solder melts and the two link halves separate, activating the sprinkler and flowing water.

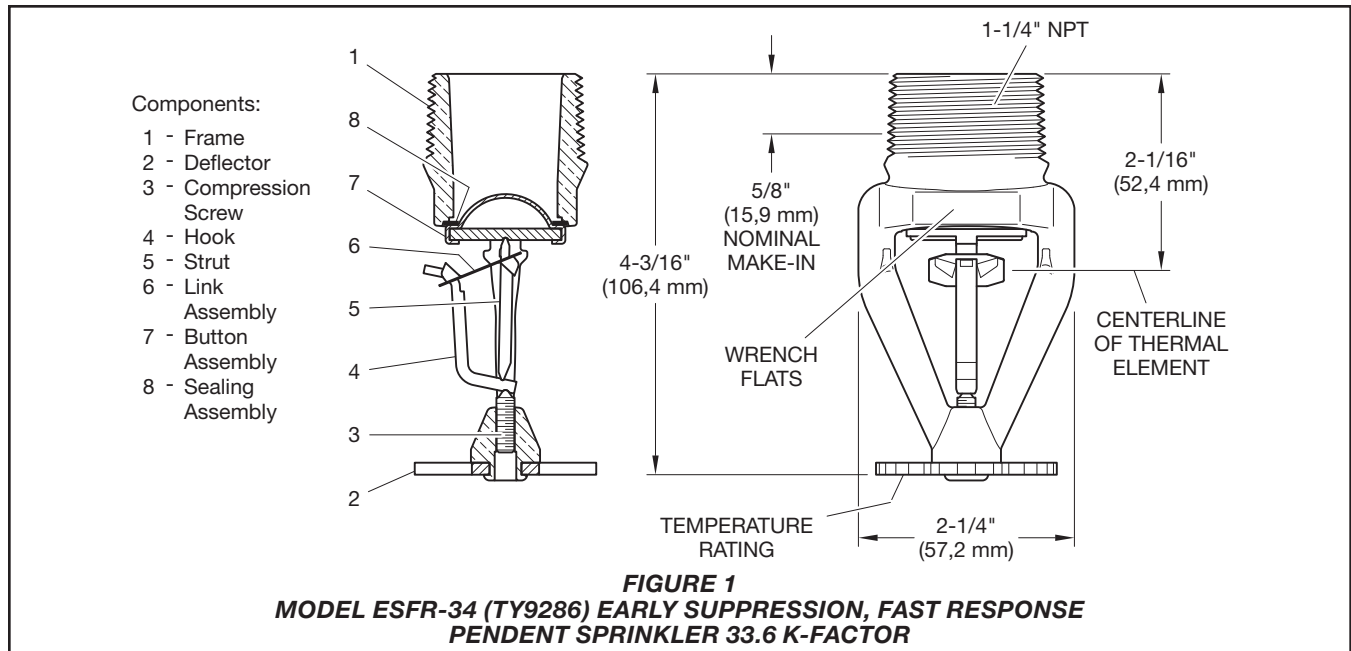

Design Criteria

The following general guidelines provided for the TYCO Model ESFR-34 Pendant Sprinklers can be used for a quick reference.

FM Global Property Loss Prevention Data Sheet 2-0, "Installation Guidelines for Automatic Sprinklers", provides the installation guidelines for the TYCO K33.6 sprinkler under the heading of Storage Sprinkler, whereas FM Global Property Loss Prevention Data Sheet 8-9, "Storage of Class 1, 2, 3, 4 and Plastic Commodities", provides its design guidelines. In all cases, the appropriate FM Global installation standard must be referenced to ensure applicability and cannot be substituted by other codes or standards. Table B provides a summary of the design and installation guidelines provided in Data Sheets 2-0 and 8-9; they are not intended to provide complete installation criteria.

Item	Description
Sprinkler Identification Number (SIN)	TY9286
K-factor, gpm/psi ^{1/2} (lpm/bar ^{1/2})	33.6 gpm/psi ^{1/2} (480 lpm/bar ^{1/2})
Thread Size	1 1/4 in. NPT or ISO 7-R 1 1/4
Sprinkler Orientation	Pendent
Maximum Working Pressure, psi (bar)	175 psi (12,1 bar)

TABLE A
MODEL ESFR-34 PENDENT SPRINKLER
TECHNICAL DATA

In addition to this technical data sheet, the following Technical Data Sheets describe other TYCO ESFR Sprinklers:

- **TFP312**
Model ESFR-25 (TY9226)
K=25.2 Pendant Sprinkler
- **TFP315**
Model ESFR-17 (TY7226)
K=16.8 Pendant Sprinkler
- **TFP316**
Model ESFR-17 (TY7126)
K=16.8 Upright Sprinkler
- **TFP317**
Model ESFR-17 (TY7223)
K=16.8 Pendant Sprinkler
- **TFP318**
Model ESFR-1 (TY6226)
K=14.0 Pendant Sprinkler
- **TFP319**
Model ESFR-14 (TY6236)
K=14.0 Pendant Sprinkler
- **TFP320**
Model ESFR-17 (TY7229)
K=16.8 Dry Pendant Sprinkler
- **TFP321**
Model ESFR-22 (TY8223)
K=22.4 Pendant Sprinkler

Roof Construction
Refer to FM 2-0, Section 2.2

Description	Specification
Sprinkler Type	QR Storage (ESFR)
Temperature Rating °F (°C)	165°F (74°C) and 212°F (100°C)
Response Type	QR
Sprinkler Position	Pendent, frame arms aligned with pipe, deflectors parallel to floor
System Type	Wet
Maximum Area of Coverage	100 ft ² (9,3 m ²)
Minimum Area of Coverage	64 ft ² (5,9 m ²)
Maximum Slope Ceiling	Up to 10°
Maximum Spacing	For buildings up to 30 ft (9,1 m): 12 ft (3,7 m) For buildings over 30 ft (9,1 m): 10 ft (3,0 m)
Minimum Spacing	8 ft (2,4 m)
Deflector Distance from Walls	Minimum of 4 in. (100 mm) from walls but no more than 1/2 the allowable distance permitted between sprinklers
Deflector to Top of Storage	Minimum of 36 in. (914 mm)
Centerline of Thermal Sensing Element to Ceiling Distance	Min. Distance: Refer to FM 2-0, Section 2.2 Max. Distance: 17 in. (432 mm)
Maximum Ceiling Height	55 ft (16,8 m)
Maximum Storage Height	50 ft (15,2 m)
Storage Arrangement	Palletized, solid piled, open frame; single row or double row
Commodity	Class I - IV, Cartoned unexpanded plastic
Sprinkler System Design	Total of 9 operating sprinklers (3 sprinklers on the most remote 3 lines) with a minimum pressure of 55 psi (3.8 bar) available at the most remote sprinkler
Obstruction Criteria	Refer to FM 2-0 Section 2.2
Minimum Aisle Width	6 ft (1,8 m)
Hose Stream Allowance and Water Supply Duration	250 gpm for 60 minutes (950 lpm for 60 minutes)

TABLE B
MODEL ESFR-34 PENDENT SPRINKLERS
FM GLOBAL COMMODITY SELECTION AND DESIGN CRITERIA

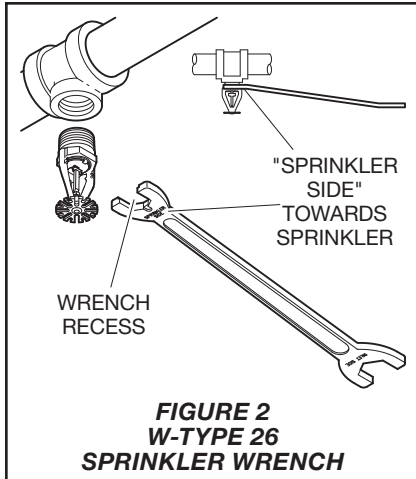

Installation

TYCO Model ESFR-34 Pendent Sprinklers must be installed in accordance with this section.

General Instructions

Damage to the fusible Link Assembly during installation can be avoided by handling the sprinkler by the frame arms only (that is, do not apply pressure to the fusible Link Assembly), and by using the appropriate sprinkler wrench. Failure to do so can lead to an unstable link assembly and premature activation of the sprinkler. Damaged sprinklers must be replaced.

A leak-tight 1 1/4 in. NPT sprinkler joint should be obtained by applying a minimum-to-maximum torque of 30 to 40 lb-ft (40,7 to 54,2 N·m). Higher levels of torque can distort the sprinkler inlet with consequent leakage or impairment of the sprinkler.

Note: Install the Model ESFR-34 Pendent Sprinkler in the pendent position (See Figure 2).

Step 1. With pipe-thread sealant applied, hand-tighten the sprinkler into the sprinkler fitting. Do not apply pressure to the Link Assembly, and handle the Model ESFR-34 Pendent Sprinkler only by the Frame arms.

Step 2. Use only the W-Type 26 Sprinkler Wrench (See Figure 2) to install the Model ESFR-34 Pendent Sprinkler. Fully engage (seat) the wrench recess on the sprinkler wrench flats (See Figure 1) and wrench-tighten.

Step 3. After installation, inspect the Link Assembly of each Model ESFR-34 Pendent Sprinkler for damage. In particular, verify that the Link Assembly and Hook are positioned as illustrated in Figures 1 and 2, and that the Link Assembly is not bent, creased, or forced out of normal position in any way. Replace damaged sprinklers.

Care and Maintenance

TYCO Model ESFR-34 Pendent Sprinklers must be maintained and serviced in accordance with this section.

Before closing a fire protection system main control valve for maintenance work on the fire protection system that it controls, obtain permission to shut down the affected fire protection system from the proper authorities and notify all personnel who may be affected by this action.

Sprinklers which are found to be leaking or exhibiting visible signs of corrosion must be replaced.

Automatic sprinklers must never be painted, plated, coated, or otherwise altered after leaving the factory. Modified sprinklers must be replaced. Sprinklers that have been exposed to corrosive products of combustion, but have not operated, should be replaced if they cannot be completely cleaned by wiping the sprinkler with a cloth or by brushing it with a soft bristle brush.

Care must be exercised to avoid damage to the sprinklers before, during, and after installation. Sprinklers damaged by dropping, striking, wrench twist/slippage, or the like, must be replaced.

The owner is responsible for the inspection, testing, and maintenance of their fire protection system and devices in compliance with this document, as well as with the applicable standards of the National Fire Protection Association (for example, NFPA 25), in addition to the standards of any authorities having jurisdiction. Contact the installing contractor or product manufacturer with any questions.

Automatic sprinkler systems are recommended to be inspected, tested, and maintained by a qualified Inspection Service in accordance with local requirements and/or national codes.

Limited Warranty

For warranty terms and conditions, visit www.tyco-fire.com.

Ordering Procedure

Contact your local distributor for availability. When placing an order, indicate the full product name and Part Number (P/N).

Sprinkler Assemblies with

1 1/4 Inch NPT Thread Connection
Specify: Model ESFR-34 (TY9286), K=33.6, Early Suppression, Fast Response Pendent Sprinkler with 1 1/4 in. NPT thread connection, (specify) temperature rating, Natural Brass, P/N (specify):

165°F (74°C)	51-681-1-165
212°F (100°C)	51-681-1-212

Special Order

Sprinkler Assemblies with

ISO 7-1 Thread Connections
Specify: Model ESFR-34 (TY9286), K=33.6, Early Suppression, Fast Response Pendent Sprinkler with ISO 7-R 1 1/4 thread connection, (specify) temperature rating, Natural Brass, P/N (specify):

165°F (74°C)	51-682-1-165
212°F (100°C)	51-682-1-212

Sprinkler Wrench

Specify: W-Type 26 Sprinkler Wrench, P/N 56-341-1-001